

METHODOLOGIES FOR ASSESSING THE IMPACT OF ITS APPLICATIONS ON CO₂ EMISSIONS

Technical
Report

V1.0

••• **EC-METI Task Force**

MARCH 2009

Table of **contents**

Preface	
1. Context	1
2. ITS applications with the potential to reduce CO ₂	4
3. Modelling the impacts of ITS on traffic and emissions	6
4. Data requirements and sources	28
5. Issues to be resolved	38
6. Recommendations for joint discussion	41
Glossary	44
Annex	46
References	55

Preface

The European Union and Japan hold a common belief that Intelligent Transport Systems (ITS) have an important role to play not only in improving the safety of road traffic and contributing to transport efficiency, but in helping to reduce its environmental impact. For this reason, a Cooperation Agreement between the European Commission (DG INFSO) and the Ministry of Economy, Trade and Industry (METI) of Japan was endorsed by the two parties in Tokyo in March 2008.

One of the aims of this Cooperation Agreement is the development of a common methodology for assessing the impact of ITS on the energy efficiency and CO₂ emissions of transport with a view to international standardisation. The parties consider that such a methodology could be a valuable tool for promoting energy efficiency in the road sector and have therefore initiated a number of activities aimed at its definition. The first step consists of a survey of existing methodologies and approaches to traffic and emissions modelling. This is intended to serve as a basis for the definition of a 'roadmap' for further research in the context of the following initiatives:

- In Europe, under the Intelligent Car Initiative, which was launched in 2006 with the general goal of making road transport safer, cleaner and smarter, a EC-METI Task Force was set up in 2008.
- In Japan, METI launched the Energy ITS project in 2008. This five-year project aims to establish an international standardised assessment methodology for measuring the effects of ITS.

The approach adopted for arriving at a common methodology is to establish a **Joint Research Task Force** with participation of scientists from both the European Union and Japan. At the conclusion of their work, the Joint Task Force is expected to produce a **Technical Report** setting out their findings and recommendations.

Both parties will work initially on an assessment of the state of the art in their own regions, after which the convergence on a common approach will be the subject of two Workshops. The first will focus on analyzing available methodologies and identifying the gaps to be filled, the second on defining a roadmap for developing the necessary technologies.

The present report presents the outcome of the first stage of work carried out by the European Task Force and is intended to offer a basis for discussion in the first joint workshop.

EC-METI Task Force:

SPENCE, Angela, Mizar
TURKSMA Siebe, Peek Traffic
SCHELLING Ab, TNO
BENZ Thomas, PTV
MEDEVIELLE Jean-Pierre, INRETS
MC CRAE Ian, TRL

European Commission:

JAASKELAINEN Juhani
BOETHIUS Eva



CHAPTER 1

Context

Intelligent Transport Systems in the EU and Japan: a shared vision

The global demand for mobility is increasing. Our societies depend heavily upon safe, secure and efficient forms of transport being available to citizens and businesses alike. However, the environmental impacts of transport – such as atmospheric pollution, with its contribution to both local air quality and global warming – have been prominent in public debate. It is therefore vital that European transport policies and research frameworks take into consideration such environmental impacts, with their severity being determined as accurately as possible. Suitable methodological frameworks are required to enable the impacts to be assessed, and these methodologies require development, validation and testing.

Information and Communications Technologies (ICTs) have been identified as having the potential to reduce the energy consumption and emissions of road vehicles, but significant results and quantitative data are still missing. So far, only a few Intelligent Transport Systems (ITS) – which are based on ICTs – have specifically addressed environmental aspects. The environmental effects of ITS strategies have generally been viewed as secondary to the effects on accidents, congestion and journey times. Tangible results are needed to support the wider deployment of ‘Green ITS’ services.

There is a clear international dimension to energy efficiency. Current negotiations on climate change should culminate in a new agreement being signed in Copenhagen in 2009 (the so-called ‘Kyoto II’). The European Union and Japan share the belief that ITS has an important role to play in helping to reduce its environmental impacts as well as in improving the safety and efficiency of road transport. In this context, a ‘Cooperation Agreement’ was endorsed by the European Commission (DG INFSO) and the Ministry of Economy, Trade and Industry (METI) of Japan in Tokyo in March 2008. This Cooperation Agreement will involve a continuous dialogue between the two regions, and research collaboration.

One of the principal aims of the Cooperation Agreement is to develop a common methodology for assessing the impacts of ITS on CO₂ emissions and the energy efficiency of transport, with a view to international standardisation. The parties consider that such a methodology would be a valuable tool for promoting energy efficiency in the road sector.

On the European side, a Task Force was appointed in July 2008 by the European Commission under the aegis of as the ‘Intelligent Car Initiative’¹. Its brief was to produce a Technical Report which could form the basis for further discussions with METI, and pave the way towards international harmonisation and standardisation. In Japan, METI launched the ‘Energy ITS’ project in 2008. This five-year project aims to establish an international standardised assessment methodology for measuring the effects of ITS.

¹ The ‘Intelligent Car Initiative’ was launched by the EC in 2006 with the goal of making road transport safer, ‘cleaner’ and ‘smarter’. It is a comprehensive approach to meeting the needs of citizens, industry and the Member States in finding common solutions to Europe’s mobility problems and improving the take-up of ICTs in road transport.



CHAPTER 1

Context

As noted above, the aim of the first stage of the work was to undertake a review of existing methodologies and approaches to traffic and emission modelling in each region. The present report presents the outcome of the European review. It provides a summary of the state of the art and offers some preliminary recommendations for further discussion.

Major European initiatives

ICT for Clean and Efficient Mobility

The topic of research in ‘ICTs for Clean and Efficient Mobility’ for all modes of transport was opened in November 2008 under the ICT priority of the European Commission’s Seventh Framework Programme (FP7). Call 4 invites proposals for new tools, systems and services to support energy-efficient driving (eco-driving). These include on-board systems and/or co-operative infrastructure and energy-optimised, adaptive traffic management for urban areas and inter-urban roads. Call 4 also includes methodologies for assessing the impacts of advanced ICTs on energy efficiency and CO₂ emissions, with the aim of achieving international harmonisation and standardisation through co-operation with Japan and the USA. Furthermore, Coordination and Support Actions cover the development of a common research agenda for energy efficiency by enhancing international cooperation.

The ICT for Clean and Efficient Mobility Working Group

Realising the need to actively promote the environmental sustainability of transport, in 2006 the eSafety Forum² established a Working Group for ICT for Clean and Efficient Mobility. This Working Group has identified seven types of ITS measure which offer the greatest potential for energy efficiency and reduction of CO₂ emissions. Detailed recommendations are offered to industry, the Member States and the European Commission concerning the deployment of these measures. The measures identified by the Working Group have been used as the basis for the review of ITS applications contained in this report.

The Energy Efficiency Task Force and the EC’s ‘Recommendation on ICT for Energy Efficiency’

In 2008, the European Commission adopted its first ‘Communication on ICTs for Energy Efficiency’. This document was subjected to wide public consultation, and a Stakeholder Group called the ‘Energy Efficiency Task Force’ was also established. On the basis of the conclusions of the Stakeholder Group, the Commission is planning to issue, in early 2009, a ‘Recommendation on ICT for Energy Efficiency’ to be addressed to the Member States and all economic actors concerned. This will identify concrete actions that will enable energy-efficient behaviour and economic benefits at all levels of society, with the aim of facilitating and accelerating the deployment of innovative ICT applications.

² The eSafety Forum is one of the three pillars of the Intelligent Car Initiative.



CHAPTER 1

Context

The main political message is that ICTs and ICT-based innovations potentially offer some of the most cost-effective means of helping Member States to reach their 2020 target for reducing carbon emissions. ICTs can also help to induce behavioural change, which will be essential for going beyond the 2020 targets, as will undoubtedly be necessary. There are opportunities not just to enable energy savings (and thus cost savings), but also to open up new markets. Accompanying the Recommendation will be an Impact Assessment and a detailed report covering multiple sectors, including transport.

About this report

This Technical Report, produced by the EC-appointed Task Force, summarises the current status in Europe with regard to methodologies for assessing the environmental impacts of road transport. It discusses traffic simulation models at 'micro', 'meso' and 'macro' levels, and their use in conjunction with models for estimating emissions. The aim is to provide the reader with a summary of the approaches available and some conclusions about their suitability for estimating the effects of 'Green ITS' services on CO₂ emissions. The Report identifies the main shortcomings of methodologies and provides some recommendations for future research. It also proposes some possible steps towards achieving a harmonised approach.

The document is structured as follows:

- Chapter 2 summarises the types of ITS application which might be considered to have the potential to reduce CO₂ emissions. It also provides some preliminary observations regarding the estimation of their impacts.
- Chapter 3 investigates the role of modelling in the estimation of CO₂ emissions. It describes the best known traffic models and emissions models, identifying their strong and weak points, and identifies aspects that require further development.
- Chapter 4 focuses on the data needs of the various models, including information which can be acquired from probe (*i.e.* instrumented) vehicles.
- Chapter 5 attempts to identify the major issues and to indicate where the current methodologies fall short of what is needed for the accurate and reliable assessment of the impact of ITS strategies on energy efficiency and CO₂ emissions.
- Chapter 6 draws up a list of recommended actions which could serve as a basis for future cooperation between Europe and Japan.

CHAPTER 2

ITS applications with the potential to reduce CO₂

This Chapter considers the principle ways in which Intelligent Transport Systems can help to reduce CO₂ emissions. It then examines specific applications which are considered to have 'green' potential.

How ITS applications can reduce CO₂ emissions

ITS applications can influence the CO₂ emissions generated by transport by means of several different strategies:

- Strategies which aim to **modify transport demand**.
This can be achieved in a number of different ways, such as encouraging travellers to use low-polluting vehicles or transport modes, or reducing the overall demand for mobility and the total distance travelled. In the case of commercial vehicles, results can be achieved through more efficient logistics. Other approaches include road charging or tolling schemes designed to favour low-CO₂ vehicles, to promote a modal shift or to discourage journeys altogether. Relevant strategies also include information services and management systems designed to increase the convenience and efficiency of public transport, as well as ITS platforms which support fleet management.
- Strategies which promote a **more CO₂-efficient use of the transport network**.
This objective can be achieved through the numerous types of traffic management and control systems which act on traffic flows. The more sophisticated applications seek not only to increase throughput and reduce congestion, but can be designed to promote optimum speeds for energy efficiency, reduce 'stop & go' behaviour, and so on. They also include the management of dedicated lanes for specific vehicle types and real-time routing which can favour more energy-efficient traffic flows. Better use of the network can also result from changes in trip timing (*i.e.* using real-time traffic information to persuade travellers to modify their departure times) and information services which support drivers looking for parking places in urban areas.
- Strategies which encourage **optimum driving behaviour**.
This category includes initiatives such as eco-driving campaigns which target individual drivers with the objective of promoting a driving style with lower CO₂ emissions. The strategy can be supported by internet-based and/or on-board instruments, as well as systems and tools embedded in the vehicle itself.

At this point, reference should be made to a further strategy which can contribute considerably to the effectiveness of many of the above applications: the so-called 'Cooperative Systems'. In recent years the European Commission has made substantial investments in the development of Cooperative Systems. These systems exploit the potential of both vehicle-based and roadside sensing technologies to gather detailed information about the driving environment: including road and weather conditions, traffic behaviour, and individual vehicle trajectories. By means of communication networks, such information can be exchanged between vehicles, and also between vehicles and the infrastructure.

CHAPTER 2

ITS applications with the potential to reduce CO₂

In the context of CO₂ reduction, Cooperative Systems can be considered 'enablers' for green versions of ITS applications. They permit enhanced monitoring of the road network and also direct communication with individual drivers, providing, for example, recommended speeds or suggested routes. The information can be 'targeted' more precisely than the existing collective messages sent via VMS (Variable Message Signs), radio or other channels, and can affect driving behaviour in rapid response to changing environmental or traffic conditions.

Review of specific ITS applications

The ITS applications which have been reviewed here fall into six main categories:

- Traffic management and control systems
- Demand and access management systems
- Navigation and travel information systems
- Driver behaviour change and eco-driving
- Logistics and fleet management systems
- Safety systems

The first five applications correspond broadly to the areas identified by the Working Group on ICT for Clean and Efficient Mobility (Kompfner *et al.*, 2008) as ITS measures which have the potential for offering environmental benefits. The last category has been included since ITS applications designed to improve road safety may also help to reduce CO₂ emissions by alleviating the congestion caused by accidents.

For each of the applications examined, the following information has been provided (this is summarised in the table in Annex I):

- A brief description of the main features and aims of the application.
- The type of road environment or scale affected by the application (*e.g.* the urban network, motorways, the regional or national scale).
- The 'green' or 'eco-friendly' potential of the application. An indication is given of the level of impact expected (this is based on recent estimates, but not on rigorous quantitative assessments).
- Whether co-operative system enhancements can be applied.
- Observations on the possibilities of applying simulation and validation methods for estimating the CO₂ emissions impact of the system.



CHAPTER 3

Modelling the impacts of ITS on traffic and emissions

Overview

This Chapter provides insight into the different types of model that are needed for the simulation of ITS measures in relation to traffic, fuel consumption and emissions (CO₂ and regulated pollutants). Traffic and communication³ models are needed to generate outputs that can be used for emission modelling. Some Existing models are briefly described.

Models create a picture of reality by describing it in a mathematical manner. They attempt to include all the most relevant parameters affecting the variables of interest; no model is ever 'correct' in an absolute sense. The primary aims of modelling in the ITS environment are to support the technical development and to demonstrate the benefits of improving traffic conditions for ITS users and society. To simulate the total process, dedicated models are required for the traffic system, the communications, the ITS application and the environmental impacts. Only when these are used in a suitable combination can meaningful results be expected. Figures 1 and 2 show the interactions between the individual parts.

The aim of traffic simulation models is to provide insight into the behaviour of vehicles on the road network. Their primary purpose is to support ITS development during the design and validation phase by yielding information on the effects on traffic patterns. Such models can also be valuable when estimating the environmental impacts of road traffic.

Separate models currently are available for treating traffic at practically all levels between sub-microscopic (detailed vehicle dynamics) and macroscopic (traffic flows on larger networks). Likewise, several communication models are available. By their nature, these generally work on a more detailed level, considering individual stations (vehicles or roadside units). The integration of the two areas is currently underway, and will be performed at the level of individual vehicles; suitable communication simulators are being connected to microscopic traffic models. The resulting model combinations will be suitable for deriving changes in macroscopic traffic characteristics. Such changes will include speed-flow-relationships, road capacities and the like; typical relationships on which macro-models are based. The resulting descriptions of traffic flow - including ITS measures - can thus be used to extend macroscopic models. They can then be applied to model the effects on road networks.

An emission model uses the results from a traffic simulation model. Depending on the level of detail of the emission model, the information required can vary widely: from aggregated traffic data, such as average speeds for road segments, to the trajectories of individual vehicles.

³ Communication models describe the dynamic processes governing data flow between communication partners such as vehicles and roadside units.

CHAPTER 3

Modelling the impacts of ITS on traffic and emissions

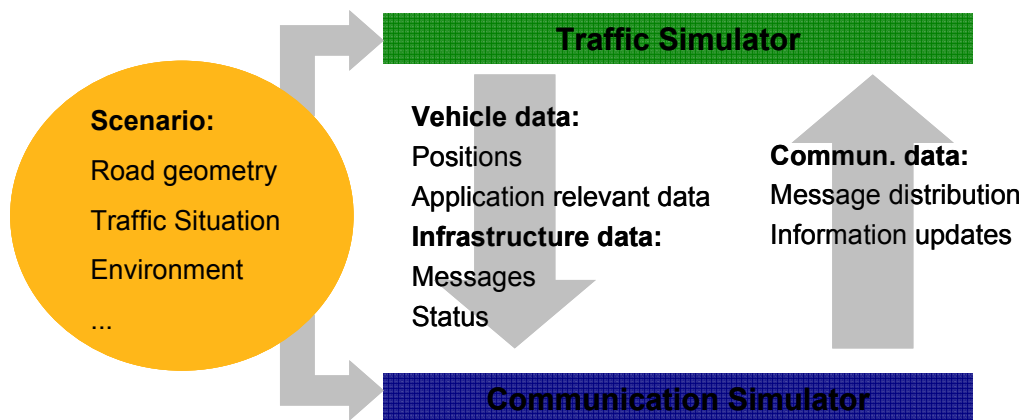

Figure 1: Interaction between traffic simulation and communication simulation.

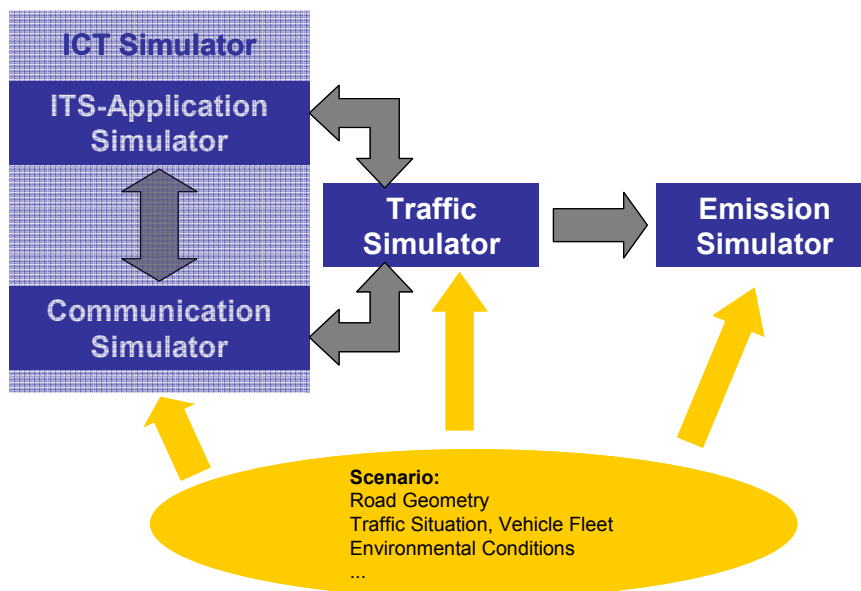

Figure 2: Relationship between the simulation of ITS applications, traffic conditions and emissions



CHAPTER 3

Modelling the impacts of ITS on traffic and emissions

Some issues associated with impact assessment

Since energy consumption, and hence CO₂ emissions, depend on detailed features of driving behaviour and vary considerably from vehicle to vehicle, estimating the environmental impact of a given ITS application is not a straightforward task. It is also evident from the discussion in the previous Chapter that ITS-based strategies for CO₂ reduction have a profound and complex impact on the whole transport system, as described below.

This impact begins with the nature of the transport demand itself, affecting the modal split (*i.e.* the choice of different modes, and especially the balance between private and public transport), as well as the quantities and types of vehicle using the transport network. It seems probable that, in response to new policies, the composition of the traffic - in terms of the fuel efficiency and fuel types of vehicles circulating on Europe's roads - will change significantly in the future.

Secondly, ITS services will affect the way vehicles are distributed across the network. The routes recommended for travel from A to B will no longer necessarily be the fastest or shortest, but the ones which permits the optimum conditions for reducing fuel consumption.

Thirdly, there are likely to be numerous 'micro-effects' caused by changes in the behaviour of individual drivers. This means that generalised assumptions and parameters used to describe the traffic will become less and less valid.

The last, and possibly most demanding aspect from the point of view of assessing the impacts of ITS, is the fact that all of the above effects will be dynamic. The ITS tools and services used to support environmentally sustainable transport provide real-time information on which travellers can base their decisions regarding trip timing, mode, route, and other behavioural choices. These will therefore adapt dynamically to conditions on the networks, changing from hour to hour and even minute to minute.

What are the implications of all these effects for the task of measuring the impact of ITS applications on CO₂ emissions? While a full reply to this question requires a detailed examination of the techniques used for quantifying the CO₂ emissions from transport (discussed later in this chapter), a certain number of preliminary observations can be made.

It is evident, first of all, that the traditional approaches for calculating traffic efficiency and emissions, based on predefined trip assignment rules, average vehicle speeds, trip times, and standard driving cycles are likely, in many cases, to be inadequate. It also seems possible that the real (wider) impact of many applications could be counter-intuitive. For example, whilst the use of dedicated traffic lanes may greatly improve the CO₂ performance of the bus or taxi fleets which use them, the resulting impacts on other vehicles, due to reduced road space and increased congestion, could well counteract this advantage. Similarly, a ramp metering system which generates queues may seem negative for CO₂ emissions, but - by smoothing traffic flows on a motorway - could improve the energy-efficiency of the traffic over a wider area. This suggests that:

- A detailed assessment is required before definitive conclusions can be drawn about the impact of any initiative on CO₂ emissions or fuel consumption.

CHAPTER 3

Modelling the impacts of ITS on traffic and emissions

- Estimates need to be based on data for a sufficiently wide geographical area to include both local and area-wide ‘knock-on’ effects.
- The assessment must include a realistic traffic composition (taking into account new vehicle models, new fuel types and hybrids).
- The assessment should be ‘multi-modal’, considering the impacts across all transport modes present on the network (in order to capture any modal shift).

At the same time, it should be noted that:

- Some useful information can be provided by the systems themselves (*e.g.* most UTC systems automatically generate reports on stopping times and queue lengths and, with the use of specialised sensing systems, queue composition).
- It is possible to obtain macro measurements, such as overall fuel sales in a city or region, which can provide an approximate comparative evaluation of the effectiveness of the strategies implemented in the area concerned.
- The vehicles using the network can themselves be instrumented and used as ‘probes’ or sensors for collecting data or measurements from which CO₂ emissions can be directly or indirectly derived. There is considerable scope for using public or private fleets (buses, taxis, public service vehicles, *etc.*) for this purpose. The issues involved in the gathering and use of such data are discussed in Chapter 4.

In a future scenario where the authorities responsible for mobility at national, regional and levels wish to promote green transport policies, they will need to have reliable ways of making comparative assessments of different ITS tools and applications on CO₂ emissions. In other words, they should be in a position to undertake ‘green audits’ of transport strategies. It will therefore be necessary to provide sound, cost-efficient and, above all, reliable methods for obtaining such information. As a first step to identifying appropriate methods, a number of different approaches to traffic simulation and emission modelling are examined in the next Chapter. Some preliminary observations on simulation and validation in relation to traffic management systems are noted below.

Modelling and validation needs

Basic modelling needs

To estimate fuel consumption (and CO₂ emissions) accurately, the following are needed:

- A detailed representation of the infrastructure.
- A detailed representation of traffic management measures.
- An accurate model of driver behaviour in response to the infrastructure and traffic management measures.
- An accurate model of engine behaviour in response to driver behaviour and infrastructure characteristics.

CHAPTER 3

Modelling the impacts of ITS on traffic and emissions

- A representation of the travel and transport demand, with details of the trip purpose and the vehicle mix.

In order to simulate the effects of ITS measures on travel/transport demand (*e.g.* modal split, route choice, and trip timing) we need a behavioural model of mode, route and trip timing in response to ITS measures and the network status (*i.e.* traffic and transport conditions).

This raises a number of questions:

- Are existing driver behaviour models sufficiently accurate (validated)?
- Can all envisaged traffic management policies be modelled?
- Do we possess a good enough database of vehicle mixes for the situations that we wish to simulate?
- Are validated vehicle engine behaviour models available?
- Is there a good model that includes modal-, route- and trip timing choices?
- What is the best way to use probe data to support CO₂ monitoring?

Modelling fuel consumption on a larger scale

Fuel consumption depends upon the details of driving behaviour which, in turn, depend upon the traffic management. To set up a simulation able to show the impact of traffic management on a useful scale (area, city or region), a great deal of modelling is required. To perform a detailed simulation of a single (complex) controlled intersection can require several days' work. Extrapolating this to a city scale (several hundred intersections), would amount to years of effort, which is clearly not a practical proposition! To effectively simulate CO₂ emissions for a large network, approximation or extrapolation is therefore essential.

Simulating the impact of traffic management systems

To simplify the analysis, simulations can be divided into three classes:

- **Fine grained**
Taking into account all the details of driver and engine behaviour, as well as route choice, but not trip motives (*i.e.* not modal split, demand management response or trip timing).
- **Stops, speed and class**
Simulations which are simplified to model energy consumption based on the number of stops made and average speed per vehicle class. This takes into account route choice, but not trip motives (as above).
- **Trip motives**
Simulations in which fuel consumption is based on flow type (free-flow, stop-and-go, stopped, *etc.*), speed, and distance. The results are based on trip motives, changing modal split and trip timing.

A note on the simulation class relevant for assessing the ITS application concerned is provided in the last column of the table in Annex 1.

CHAPTER 3

Modelling the impacts of ITS on traffic and emissions

Traffic models

The purpose of traffic models, in general, is to provide numerical information on the amount and characteristics of vehicular traffic. The information required ranges from large-scale considerations over long time horizons, such as the total vehicle mileage per country per year, down to information on the speed profiles of individual vehicles. Different approaches have therefore been developed to tackle such diverse problems. To clarify the whole range of requirements, the following paragraph describes a typical traffic model. Such a model requires a representation of the mobility (trip) demand and the transport 'supply', i.e. the road network and public transport services available. The term *simulation model* will be used to describe the algorithms from which a traffic model can be created, and their implementation.

A basic traffic model makes assumptions about the number of vehicles on each road link by assigning the traffic demand to the network. The traffic demand is expressed as the number of trips described in terms of their origins and destinations. After selecting the traffic mode, such as car, tram or bicycle - a process called 'modal choice' - the trips per mode are known. The next step is to assign these to the network by a selection of possible routes, and to determine the shares of the possible routes. This assignment process assumes driver behaviour which respect economic principles for reaching an optimum (e.g. minimising overall trip time). After this step, the amount of traffic per network link is known. In a multi-modal model public transport services and the road network exist jointly in one model. Such a traffic model can vary in geographic scale, from a small community up to a whole country. It should also be noted that a model can be *dynamic*, in the sense that it separates time intervals (generally one-hour intervals) or *static* (for the traffic of a typical working day). The latter are still the more common for transport planning.

A traffic model, as described above, does not represent individual vehicles but only streams of vehicles, denoted as traffic flow in vehicles per hour or vehicles per day. Therefore, the respective simulation models are labelled *macroscopic*. They represent traffic using the macroscopic parameters traffic flow (vehicles per hour), traffic density (vehicles per kilometre) and average speed. They may, but do not necessarily, distinguish between vehicle types (passenger cars and trucks). The purpose of such macroscopic models lies mostly in determining the amount of traffic on the links of a network.

In contrast to this, *microscopic* models deal with the movements of individual vehicles. An essential property of all micro-simulation traffic models is the prediction of the operation of individual vehicles in real time, over a series of short time intervals, and using models of driver behaviour such as car-following, gap acceptance, lane-changing and signal behaviour theories, rather than aggregate relationships. Vehicle operation is usually defined in terms of speed and acceleration for a number of pre-defined or user-defined vehicle types. Provided the road network and all its features are represented in the modelling system, accurate representation of real life traffic will depend on the precision in simulating the following (TfL, 2003; Dowling *et. al.*, 2004):

- The arrival at vehicles at the boundary of the modelling domain.
- Car-following - the way vehicles follow those in front and react to changes in speed.

CHAPTER 3

Modelling the impacts of ITS on traffic and emissions

- Lane changing - vehicles changing lanes to overtake slower traffic as queues develop ahead, or moving to a more suitable lane based on turning movement and destination.
- Gap acceptance – micro-simulation tools can model complex gap-acceptance situations in urban traffic, such as filter right-turns at signalised junctions, minor movements at give-way or stop signs, traffic entering priority roundabouts and traffic merging situations.

Early approaches were mainly designed to reproduce the vehicular stream on road sections. Increasing computing power and other developments have made more complex scenarios possible. Modern simulation models even treat processes classically - associated with macroscopic models like route choice and assignment in road networks. At their core, however, is the reproduction of the movement of individual vehicles.

A third category of models are *mesoscopic* ones. These treat individual vehicles and determine their movement on the basis of macroscopic characteristics. They have advantages in terms of run time over classical microscopic models. However, they often lack details which are essential to the investigation being performed. Another approach to improve run time from microscopic models is to combine microscopic and macroscopic models to form hybrid simulators. These perform their tasks with the greater detail of microscopic models where needed, and in other parts of the network they apply macroscopic approaches.

There are various approaches to determining vehicle movements. Generally, models with a higher level of detail are able to cover smaller parts of networks, while less detailed models tend to cover larger road networks. The selection of a suitable assignment model must reflect the purpose of the application. While complex movement models describe driver behaviour in detail, more generalised approaches use less detail and less variation between individuals for the benefit of shorter run times and less memory demand in order to handle larger networks. Examples are models reflecting individual driver behaviour by psycho-physiological approaches in detail; at the other end of the scale are agent-based approaches which are far less computing-intensive. The “right” model for an application is always the one that is best suited for the purpose of the investigation.

However, experience over the last decades has shown that the increase in computing power offsets the run-time requirements of microscopic models. In most cases, they are best suited for ITS evaluations.

In the investigation of ITS impacts traffic models serve two purposes: they directly provide traffic effects and also generate the data required for the simulation of communication models.

The data required for traffic simulation depend heavily on the type of model employed. While macroscopic models need information about the area modelled, such as the number of inhabitants per zone, microscopic models need to be validated against real-world data on traffic flow. Typical input data include speed distributions, routing information and time-dependent volumes. Traffic regulations also form an integral part of a microscopic model.

In order to work satisfactorily, traffic models must be calibrated and validated properly for the given task. It must be proven that they recreate traffic as it happens in reality. Data for such calibrations are usually traffic data sampled on cross-sections. The minimum requirement for



CHAPTER 3

Modelling the impacts of ITS on traffic and emissions

a (microscopic) model is to correctly reproduce macroscopic features such as speed-volume relationships and speed distributions. For the investigation of ITS measures, however, available traffic measurements yield insufficient detailed data. Only dedicated experiments will provide such data, as e.g. speed profiles of equipped vs. non-equipped vehicles. Driver behaviour is, in many cases, important, which adds another dimension to the required data. It is expected that only large-scale experiments provide the kind and amount of data needed for sound calibration of microscopic models. In such Field Operational Tests (FOTs) the focus can be put on those data which are still missing and essential for high-quality simulation results.

Finally, the following table lists some examples of traffic simulation models. The ones mentioned constitute only a small subset of all models employed in Europe. However, they do have a proven history of application in the context of environmental impact modelling

Communication models

When evaluating ITS, especially cooperative systems, an important aspect is the effectiveness of the communication between vehicles and/or infrastructure. Only if this communication performs as intended can the ITS effectively influence traffic. It is therefore essential to include simulation models for the communication part when evaluating ITS.

Simulation models for communication networks describe the highly dynamic processes governing data flow between communication partners like vehicles and/or roadside units. They detect which stations are able to exchange information and simulate the data exchange, including the protocols for handling the data flow. Their basis is the physics of radio wave propagation. As a result, they establish which information is successfully transferred between which stations.

The basic information for a simulation scenario may include the topography (*e.g.* for shadowing). The dynamic information, at least for C2X applications, is provided by microscopic traffic flow models in the form of (dynamic) locations of the stations (vehicles) and the data to be transmitted.

The results of communication simulation models indicate the appropriateness of the chosen communication system, including hardware and software. They provide insight into the requirements for the design of hardware (*e.g.* required signal strength) and software (*e.g.* protocols).

CHAPTER 3

Modelling the impacts of ITS on traffic and emissions

Table 1: Examples of traffic simulation models

Name	Developer	Typical Application	Remark
ARCHISIM	INRETS	ITS investigation	Used in several EU research projects
ITS modeller	TNO	Evaluation of ITS	A modelling platform designed to integrate a number of micro-simulators
V2X simulator	Daimler	Investigations of C2X interfaces.	Based on (macroscopic) three phase theory, interface to C2X model
VISSIM	PTV	Urban and motorway, any measure influencing vehicles	Commercially available tool, open interfaces for driver behaviour
SATURN		Assignment of demand to network	Trip assignment model
VISUM	PTV	Creation and handling of traffic models, demand, modal split, assignment etc.	Commercially available Traffic assignment model, widely used, also as a “data platform”
AIMSUN	TSS	Any application influencing driver-vehicle behaviour, from traffic planning to ITS evaluation	Commercially available micro-simulation
PARAMICS	SIAS & Quadstone	Any application influencing driver behaviour, from traffic planning to ITS evaluation	Commercially available micro-simulation
SISTIM	TRL	High-speed road network	Largely used for UK motorway evaluations and within EU research projects

Emission models

Sources and pollutants

Various atmospheric pollutants are emitted from road vehicles as a result of combustion and other processes. The main processes - and the pollutants concerned - are summarised in Table 2. Exhaust emissions of carbon monoxide (CO), hydrocarbons (HC), oxides of nitrogen (NO_x) and total particulate matter (PM) are regulated by EU Directives, as are evaporative emissions of volatile organic compounds (VOCs). However, vehicle exhaust also contains pollutants which are not regulated, including the greenhouse gases carbon dioxide (CO₂), methane (CH₄) and nitrous oxide (N₂O). With the exception of CO₂, unregulated pollutants have been characterised in less detail than the regulated ones.

CHAPTER 3

Modelling the impacts of ITS on traffic and emissions

Table 2: Vehicle emission sources and pollutants.

Source/process	Pollutant(s) emitted
Hot and cold-start exhaust emissions	Regulated pollutants } CO HC NO _x PM
	Unregulated pollutants, including the greenhouse gases } CO ₂ CH ₄ N ₂ O
Evaporative emissions	VOCs (regulated)
Tyre and brake wear Road surface wear Resuspension	} PM (unregulated)

The emission levels associated with the processes in Table 2 are dependent upon many factors, including vehicle-related factors such as model, size, fuel type, technology level and mileage, and operational factors such as speed, acceleration, gear selection, road gradient and ambient temperature.

Overview of modelling approaches

In some European countries estimates of road transport emissions have been made on a national basis, and more locally as part of pollution impact studies, since the 1970s. The methods used have gradually been improved and developed with respect to the amount, type and quality of data available.

All emission models must take into account the various factors affecting emissions, although the manner in which they do so, and the level of detailed involved, can vary substantially. Models for estimating emissions from road vehicles can therefore be classified in several different ways, although models can generally be described in terms of the following (Boulter *et al.*, 2007, Barlow *et al.*, 2007):

- The type of application, such as estimating local air quality, emission inventories).
- The geographical scale of application, from an individual street to a country.
- The operational basis for estimating emissions. For example, some models use vehicle speed, some use a combination of speed and acceleration (or more variables), and others use vehicle power.
- The nature of the emission calculation. Some models use continuous functions to describe emissions, whereas others use discrete values.

CHAPTER 3

Modelling the impacts of ITS on traffic and emissions

A number of generic model types, with examples of specific models, are summarised in Table 3. These generic types of model are discussed in more detail in the following paragraphs.

Aggregated emission factor models

Aggregated emission factor models operate at the simplest level, with a single emission factor being used to represent a particular type of vehicle and a general type of driving – the traditional distinction is between urban roads, rural roads and motorways. Vehicle operation is therefore only taken into account at a very rudimentary level, and the approach cannot be used to determine emissions for situations which are not explicitly defined. The emission factors are calculated as mean values of measurements on a number of vehicles over given driving cycles, and are usually stated in terms of the mass of pollutant emitted per vehicle and per unit distance ($\text{g vehicle}^{-1} \text{ km}^{-1}$) or per unit of fuel consumed (g litre^{-1}). Given their simplicity, these factors are of most use in applications on a large spatial scale, such as national and regional emissions inventories, where little detailed information on vehicle operation is required.

Table 3: Models for estimating emissions from light-duty vehicles⁴

Generic type	Example	Type of emission factor/function	Type of input data	Typical application
Aggregated emission factors	COPERT	Discrete	Road type	Emission inventories, EIA ⁵ , SEA ⁶
Average speed	COPERT, DMRB, MOBILE	Continuous	Average trip speed	Emission inventories, dispersion modelling
Adjusted average speed	TEE	Continuous	Average speed, congestion level	Emission inventories, dispersion modelling
Traffic situation	HBEFA ARTEMIS	Discrete	Road type, speed limit, level of congestion	Inventories, EIA, SEA, area-wide assessment of urban traffic management schemes, dispersion modelling
Multiple linear regression	VERSIT+	Discrete	Driving pattern	Emission inventories, dispersion modelling
'Simple' modal	UROPOL	Discrete	Distribution of driving modes	Local assessment of urban traffic management schemes
Instantaneous, speed-based	MODEM	Discrete	Driving pattern	Detailed temporal and spatial analysis of emissions, dispersion modelling
Instantaneous, power-based	VeTESS, PHEM, CMEM	Discrete	Driving pattern, gradient, vehicle data	Detailed temporal and spatial analysis of emissions, dispersion modelling

⁴ Most of the models listed also address other types of vehicle, such as heavy goods vehicles and buses.

⁵ EIA = environmental impact assessment.

⁶ SEA = strategic environmental assessment.

CHAPTER 3

Modelling the impacts of ITS on traffic and emissions

Average-speed models

Average-speed emission functions for road vehicles are also widely applied in regional and national inventories, but are also currently used in a large proportion of local air pollution prediction models. The average-speed approach is exemplified by the model incorporated within the UK Design Manual for Roads and Bridges (DMRB) (Highways Agency *et al.*, 2007) and the European Environment Agency's COPERT model (Gkatzoflias *et al.*, 2007). Average-speed models are based upon the principle that the average emission factor for a certain pollutant and a given type of vehicle varies according to the average speed during a trip. The emission factor is again usually stated in grams per vehicle-kilometre ($\text{g vehicle}^{-1} \text{km}^{-1}$). Figures 3a and 3b show how a continuous average-speed emission function is fitted to the emission factors measured for several vehicles over a range of driving cycles, with each cycle representing a specific type of driving, including stops, starts, accelerations and decelerations. It is also evident from this simple example that the data scatter, and thus uncertainty, is considerably less for CO_2 , than other exhaust emission components.

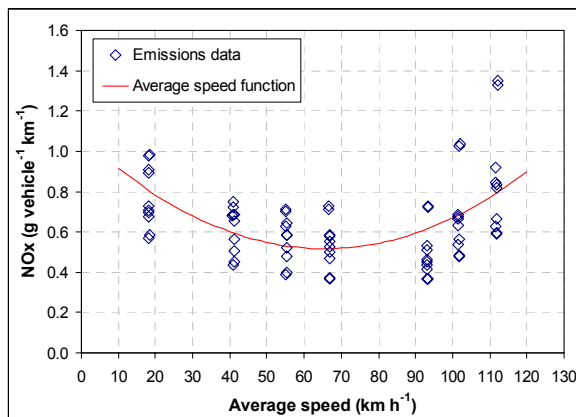

Figure 3a: Average-speed emission function (line) for NO_x emissions from Euro III diesel cars <2.0 litres. The blue points show the underlying emission measurements (Barlow *et al.*, 2001).

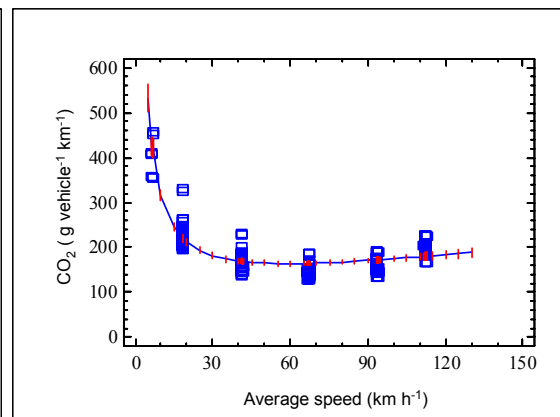

Figure 3b: Average-speed emission function (line) for CO_2 emissions Euro II medium size petrol car with the base data and 95% confidence intervals (Barlow *et al.*, 2001).

A number of factors have contributed the widespread use of average-speed approach. For example, it is one of the oldest approaches, the models are comparatively easy to use, and there is a reasonably close correspondence between the required model inputs and the data generally available to users. In principle, the input is the trip-based average speed, although in practice it is also common for local speed measurements taken at discrete locations to be used. However, there are considered to be a number of limitations associated with average-speed models, including the following:

CHAPTER 3

Modelling the impacts of ITS on traffic and emissions

- Trips having very different vehicle operational⁷ characteristics, and therefore different emission levels, can have the same average speed. Clearly, all the types of operation associated with a given average speed cannot be accounted for by the use of a single emission factor. This is less of a problem at higher average speeds, for which the possible variations in vehicle operation are more limited, but at lower average speeds the range of possible operational conditions associated with a given average speed is much greater.
- In response to the tightening of emission control legislation, vehicles have been equipped with increasingly sophisticated after-treatment devices, manufacturer-specific engine management software, and regenerating after-treatment systems. For such vehicles a large proportion of the total emission during a trip can be emitted as very short, sharp peaks, often occurring during gear changes and periods of high acceleration. Average speed has therefore become a less reliable indicator of emissions for the newest generation of vehicles; the average-speed model provides an impression of reality that is often too simplistic.
- The shape of an average-speed function is not fundamental, but depends on, amongst other factors, the types of cycle used in development of the functions. For example, each cycle used in the development of the functions typically represents a given real-world driving condition, but the real distribution of these driving conditions is not normally taken into account (*e.g.* via weightings).
- Average-speed models do not allow for detailed spatial resolution in emission predictions, and this is an important drawback in dispersion modelling.

One of the limitations of average-speed models mentioned earlier was the inability to account for the ranges of vehicle operation and emission behaviour which can be observed for a given average speed. In this context the concept of ‘cycle dynamics’ has become useful for emission model developers (*e.g.* Sturm *et al.*, 1998).

In qualitative terms, cycle dynamics can be thought of as the ‘aggressiveness’ of driving, or the extent of ‘transient’⁸ operation in a driving pattern. Quantitatively, the term refers to the variation in various properties or statistical descriptors of a vehicle operation pattern. Researchers have examined a range of variables in an attempt to understand the links between cycle dynamics and emissions. As the vehicle operation information available to model users and developers has tended to be very limited, and almost invariably speed-based (*e.g.* spot speeds measured using traffic-counting equipment), interest has inevitably focussed on parameters which describe speed variation in some way. Some of the more useful parameters appear to be relative positive acceleration (Ericsson, 2000) and positive mean acceleration (Osses *et al.*, 2002). However, there are even problems with this simplest concept of cycle dynamics, for example:

⁷ In this context, the term ‘vehicle operation’ refers to a wide range of parameters which describe the way in which a driver controls a vehicle (*e.g.* average speed, maximum speed, acceleration pattern, gear-change pattern), as well as the way in which the vehicle responds (*e.g.* engine speed, engine load).

⁸ In this context, the term ‘transient’ refers to a driving cycle in which the operation of the vehicle is continuously varying, as opposed to being in a steady-state.

CHAPTER 3

Modelling the impacts of ITS on traffic and emissions

- Most model users have little or no straightforward means of relating to descriptors of variation in vehicle operation, as these describe the properties of entire driving patterns (of course, this does not only affect speed). Most model users will only tend to have traffic flow and average speed information, and relationships between these parameters and those describing cycle dynamics on urban roads are not well-established. As a consequence, cycle dynamics has not usually been taken into account quantitatively.
- Several studies have concluded that emissions should be described in terms of engine speed, load, power, and the changes in these parameters, not just variables relating to vehicle speed (Leung and Williams, 2000; Kean *et al.*, 2003).

Nevertheless, the concept is a useful one, especially when there is a need to discuss more advanced forms of modelling than the average-speed approach.

‘Corrected’ average-speed models

The TEE (Traffic Energy and Emissions) model (Negrenti, 1998) incorporates a ‘corrected-average-speed’ modelling approach. The model assumes that the effect of congestion on emissions at a certain average speed can be expressed by means of a ‘correction factor’ derived from average speed, green time percentage, link length, and traffic density. The emission factor for the average speed is then adjusted using the correction factor. The congestion level is used to calculate the fractions of time spent during cruising, acceleration, deceleration and idling, and the end result is a reconstructed speed profile produced by the model itself. In fact, the TEE model uses emission factors from a simple instantaneous model (MODEM – see later) to calculate emissions for each of the phases, based on the reconstructed profile. The limitations of this part of the approach are discussed in the Section on simple instantaneous models.

Traffic situation models

One alternative approach for incorporating both speed and cycle dynamics into emission estimations involves ‘traffic situation’ modelling, whereby cycle average emission rates are correlated with various driving cycle parameters. These, in turn, are referenced to specific traffic situations which are known by the model user. Different traffic situations relate to conditions for which there is a specific emission problem, and for which the average speed may not be the best indicator of emissions. Traffic situation models tend to be best suited to local applications, in which emission estimates are required for individual road links, but can also be used for regional and national inventories.

The user must be able to relate to the way in which the traffic situations are defined in the model. For example, the Handbook of Emission Factors (HBEFA), used in Germany, Austria and Switzerland or the ARTEMIS model (Boulter and McCrae, 2009) recently developed as part of a European research project and currently used in France, Sweden and several other countries, are, s based on reference emission factors for different categories of vehicle (Based on European state-of-the art and on large databases, these emissions factors are considered as the most representative in Europe). Each emission factor is associated with a particular traffic situation, characterised by the features of the section of road concerned (*e.g.* ‘motorway with



CHAPTER 3

Modelling the impacts of ITS on traffic and emissions

120 km/h limit', 'main road outside built-up area'). The speed variation (dynamics) variable is not quantified by the user, but is defined by a textual description (*e.g.* 'free-flow', 'stop and go') of the type of traffic situation to which an emission factor is applicable (INFRAS, 2004). As with any other model, the emission factors produced by the Handbook for the various vehicle categories must then be weighted according to traffic flow and composition.

However, asking the user to define the traffic situation using a textual description of speed variation or dynamics may lead to inconsistencies in interpretation. Furthermore, there are no universally accepted definitions for traffic situations - the Artemis works in that direction have however enabled significant progress towards a coherent, and agreed traffic situation scheme, based to the actual traffic engineering practices in Europe. Also, there are likely significant differences between the absolute characteristics of traffic in different cities. In addition, the Handbook employs definitions which are road- or traffic-based, rather than emissions-based. Although it is known that there are relationships between the characteristics of the road (*e.g.* number of lanes, carriageway width, topography), the prevailing traffic (*e.g.* flow, composition) and the operation of vehicles, the relationships with vehicle emissions are less well known. One should, however, stress that these difficulties and criticisms also concern the other estimation approaches, even if at a lower level of complexity.

Multiple linear regression models

The VERSIT+ model (Smit *et al.*, 2005) employs a weighted-least-square multiple regression approach to model emissions, based on tests on a large number of vehicles over more than 50 different driving cycles. Within the model, each driving cycle used is characterised by a large number of descriptive parameters (*e.g.* average speed, RPA, number of stops per km) and their derivatives. For each pollutant and vehicle category a regression model is fitted to the average emission values over the various driving cycles, resulting in the determination of the descriptive variables which are the best predictors of emissions (the group of descriptors being different in each case). A weighting is also applied to each emission value, based on the number of vehicles tested over each cycle and the inter-dependence of cycle variables. The VERSIT+ model requires a driving pattern as the input, from which it calculates the same range of descriptive variables and estimates emissions based on the regression results. The physical meaning of the variables may not necessarily be known. As with the other models requiring a driving pattern as the input, the use of the model is currently restricted to a comparatively small number of users.

Modal models

In modal models emission factors are allocated to the specific modes of vehicle operation encountered during a trip. Different types of modal model are in use, and the terminology used can be rather confusing. In the simpler type of modal model, vehicle operation is defined in terms of a relatively small number of modes - typically 'idle', 'acceleration', 'deceleration' and 'cruise'. A number of more detailed modal models aim to provide a more precise description of vehicle emission behaviour by relating emission rates to vehicle operation during a series of short time steps (often one second). However, several different terms (as well as modal) have been used to describe the more detailed type of model, including 'instantaneous', 'microscale', 'continuous' and 'on-line' (De Haan and Keller, 2000). Such models still tend to be discrete

CHAPTER 3

Modelling the impacts of ITS on traffic and emissions

emission values in the calculation, and therefore the term ‘instantaneous’ is something of a misnomer. However, as the term is in common use it is retained here.

‘Simple’ modal models

As mentioned above, simple modal models categorise vehicle operation according to a relatively small number of modes. For each of the modes the emission rate for a given vehicle category and pollutant is assumed to be fixed, and the total emission during a trip, or on a section of road, is calculated by weighting each modal emission rate by the time spent in the mode. For example, the Urban Road Pollution (UROPOL) model (Hassounah and Miller, 1995) combines the numbers of vehicles that are accelerating, decelerating, queuing or cruising at any point along a road segment, with emission rates relating to each driving mode. The coarse model approach has usually been used to determine the impacts of traffic control measures and signal improvements (*e.g.* Coelho *et al.*, 2005). A similar approach has been used by, for example, Frey *et al.* (2001) and Hung *et al.* (2005).

Instantaneous models

Atjay and Weilenmann (2004) stated that the aim of instantaneous emission modelling is to map emission measurements from tests on a chassis dynamometer or an engine test bed in a neutral way. In theory, the advantages of instantaneous models include the following:

- Emissions can be calculated for any vehicle operation profile specified by the model user, and thus new emission factors can be generated without the need for further testing.
- The models inherently take into account the dynamics of driving cycles, and can therefore be used to explain some of the variability in emissions associated with given average speeds.
- The models allow emissions to be resolved spatially, and thus have the potential to lead to improvements in the prediction of air pollution.

Some instantaneous models, especially the older ones, relate fuel consumption and/or emissions to vehicle speed and acceleration during a driving cycle, typically at one-second intervals. Other models use some description of the engine power requirement. However, it must be noted that there are a number of fundamental problems associated with the older generation of instantaneous models. For example, it is extremely difficult to measure emissions on a continuous basis with a high degree of precision, and then it is not straightforward to allocate those emission values to the correct operating conditions. Atjay and Weilenmann (2004) noted that, during measurement in the laboratory, an emission signal is dynamically delayed and smoothed, and this makes it difficult to align the emissions signal with the vehicle operating conditions. Such distortions have not been fully taken into account in instantaneous models until relatively recently.

Some consideration also ought to be given to the model user. In order to apply instantaneous models detailed and precise measurements of vehicle operation and location are required, otherwise any potential benefits may be lost. This is likely to be rather difficult for many model users; as such information is relatively expensive to collect. As a consequence, the use of instantaneous models has largely been restricted to the research community. However, with

CHAPTER 3

Modelling the impacts of ITS on traffic and emissions

the growth in the use of microsimulation traffic models (largely brought about through the improvements in computing capacity), the availability of these data is improving.

PHEM

The ARTEMIS project and the COST Action 346⁹ provided a great deal of insight into the emission behaviour of modern vehicles. One of the main aims of ARTEMIS and the COST Action was to develop a model capable of accurately simulating emission factors for all types of vehicles over any driving pattern and for various vehicle loads and gradients; the latter greatly influence driving behaviour and emission levels. The resulting tool - PHEM (**P**assenger car and **H**eavy-duty **E**mission **M**odel) - estimates fuel consumption and emissions based on the instantaneous engine power demand and engine speed during a driving pattern specified by the user (Rexeis *et al.*, 2005). The PHEM model thus has the capability of providing suitable emission resolution for use with micro-simulation traffic models.

The methodology for PHEM was selected following an extensive literature review and feasibility study by Hausberger (1998). The review noted that most HDV models have employed a similar methodology – based on engine power demand and speed - to simulate emissions, and this general approach was also adopted for PHEM. Figure 4 shows the structure of the model. The main inputs are a user-defined driving pattern and a file describing vehicle characteristics. For every second of the driving pattern PHEM calculates the actual engine power demand based upon vehicle driving resistances and transmission losses, and calculates the actual engine speed based upon transmission ratios and a gear-shift model. The engine power and speed are then used to reference the appropriate emission (and fuel consumption) values from steady-state engine maps. The emission behaviour over transient driving patterns is then taken into consideration by ‘transient correction functions’ which adjust the second-by-second steady-state emission values according to parameters describing the dynamics of the driving pattern.

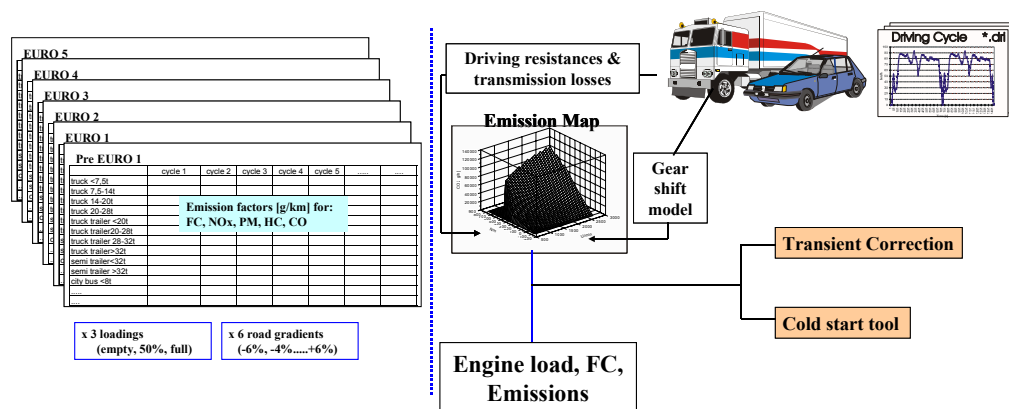

Figure 4: Structure of PHEM (Rexeis *et al.*, 2005).

⁹ <http://www.cordis.lu/cost-transport/src/cost-346.htm>

CHAPTER 3

Modelling the impacts of ITS on traffic and emissions

The outputs from the model are engine power, engine speed, fuel consumption and emissions of CO, CO₂, HC, NO_x and PM every second, as well as average values for the entire driving pattern.

CMEM

Barth *et al.* (2001) describe the development of a 'Comprehensive Modal Emissions Model' (CMEM). The model is capable of predicting second-by-second exhaust (and engine-out) emissions and fuel consumption, and is comprehensive in the sense that it is able to predict emissions for a wide range of vehicle and technology categories, and in various states of condition (*e.g.* properly functioning, deteriorated, malfunctioning). In fact, the main purpose of CMEM is to predict vehicle exhaust emissions associated with different modes of vehicle operation such as idle, cruise, acceleration, and deceleration. In this sense CMEM is ostensibly closer to the simpler type of modal model described earlier. Nevertheless, the model is rather detailed, takes into account engine power, includes aspects of vehicle operation such as variable starting conditions (cold-start, warm start) and off-cycle driving, and operates on a temporal level which is similar to that of other instantaneous models.

CMEM uses what is termed by Barth *et al.* (2001) as a 'physical power-demand' modal modelling approach based on a 'parameterised analytical representation of emissions production'. What this means is that the production of emissions is broken down into components which correspond to different physical processes, and each component is then modelled separately using various parameters which are characteristic of the process. These parameters vary according to the vehicle type, engine and emission technology. The majority of the parameters are readily available (*e.g.* vehicle mass, engine size, aerodynamic drag coefficient), but some key parameters must be deduced from a test programme, although the testing involved is much less extensive than creating emission maps for a wide range of vehicle operating points.

Using this type of modelling approach, models must be established for the different engine and emission-control technologies in the vehicle fleet. Once these models have been established, it is necessary to identify the key parameters in each component of the models for characterising vehicle operation and emissions production. A critical component of the approach is that emission control malfunction and deterioration are explicitly modelled. The correct modelling of high-emitting vehicles is also an important part of the approach. In order to predict emission rates, the next step is to combine the models with vehicle operating parameters that are characteristic of real-world driving, including environmental factors such as ambient temperature and air density, as well as dynamic factors such as commanded acceleration, road load, road gradient and the use of auxiliaries (*e.g.* air conditioning, electric loads). The predicted emission rates can then be compared directly to measured emissions data, and the model parameters or components can be adjusted to establish an optimal fit. This calibration/validation process occurs iteratively until the models are well developed (Barth *et al.*, 2001).

The complete model is composed of six modules, as shown in Figure 5 by the six square boxes. The model requires two groups of input (the rounded boxes): (A) input operating variables and (B) model parameters. There are also four operating conditions in the model (the ovals): (a)

CHAPTER 3

Modelling the impacts of ITS on traffic and emissions

variable soak time start, (b) stoichiometric operation, (c) enrichment and (d) 'enleanment'. Hot-stabilised vehicle operation encompasses conditions (b), (c) and (d). The model determines in which condition the vehicle is operating at a given moment by comparing the vehicle power demand with threshold values.

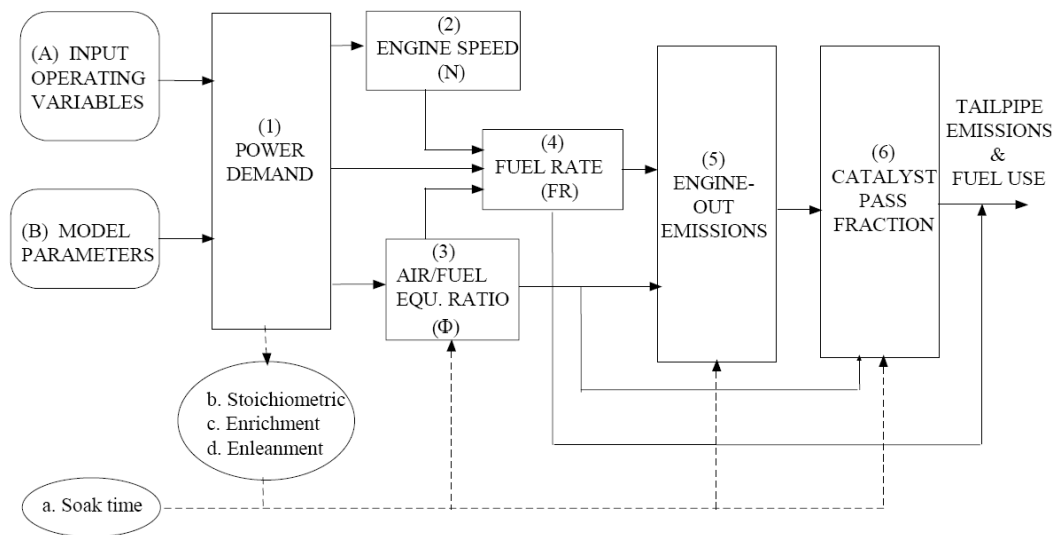

Figure 5: CMEM structure (Barth *et al.*, 2001).

The vehicle power demand (1) is determined based on operating variables (A) and specific vehicle parameters (B). All other modules require the input of additional vehicle parameters derived from dynamometer measurements, as well as the engine power demand calculated by the model. The core of the model is the fuel rate calculation (4). It is a function of power demand (1), engine speed (2), and air: fuel ratio (3). Engine speed is determined based on the vehicle speed, the gear shift schedule and the power demand.

The CMEM software is well documented by Barth *et al.* (2001). The model is available as executable code for both the PC environment (running from a DOS command line) and the UNIX environment. A more user-friendly, graphical interface is available in Microsoft Access. CMEM can be ordered via internet¹⁰ at a cost of US\$20.

MOVES

The USEPA's MOrtor Vehicle Emission Simulator (MOVES)¹¹ is designed to be used to estimate inventories and projections for road transport. The model features a number of novel approaches including a modal emission rate approach as a lead-up to finer-scale modelling;

¹⁰ <http://pah.cert.ucr.edu/cmем/>

¹¹ Full details of the MOVES model are available on the dedicated MOVES website - <http://www.epa.gov/otaq/ngm.htm>



CHAPTER 3

Modelling the impacts of ITS on traffic and emissions

modelling a broad array of advanced technology vehicles; explicitly modelling periods of extended idling (*e.g.* heavy-duty 'hostelling'); relying primarily on second-by-second data to develop emission rates; and including well-to-pump energy emission estimates to enable life-cycle analysis (Koupal *et al.*, 2005).

The first version of MOVES included a range of fuels including gasoline (conventional, E10 and reformulated), diesel (conventional, bio diesel and Fischer-Tropsch), CNG, E85, M85, LPG, and electricity. The model is applicable to a range of vehicle technologies including conventional internal combustion (all fuels), advanced internal combustion (gas and diesel), moderate hybrid-electric (gas and diesel), full hybrid-electric (gas and diesel) and dedicated electric. The model is a, however, currently restricted to the estimation of nitrous oxide (N₂O), and methane (CH₄) emissions.

The next version of the model is planned for release in late-2008. It is envisaged that this will include other pollutants (non-exhaust emissions, CO, HC, NO_x, PM, toxics, CO₂, NH₃ and SO₂), and that that MOVES will eventually replace the existing USEPA average-speed model MOBILE6. Future versions will also operate at smaller geographic scales. It is also intended that the model will be extended to include hydrogen (gaseous and liquid), once well-to-pump pathway inputs become available.

MOVES uses a second-by-second databases of emission rates (grammes per second). However, within the databases the individual bins (cells) are based upon a calculated vehicle-specific power (VSP), on a second-by-second basis. Thus, the driving cycle (speed and acceleration at each second of operation) must initially be converted into a number of VSP bins. Knowledge of the VSP bin for each second of operation allows the derivation of vehicle emissions (or fuel consumption) for each second.

Discussion

Existing emissions models are sometimes based on a rather limited number of emissions measurements and generally refer to average driving cycles which were conceived to represent traffic conditions and driving behaviour. Due to the cost of the experiments, the representation of traffic conditions and behaviour is envisaged with just a few driving cycles. The models therefore cannot easily reproduce the detailed features of traffic behaviour and are not designed to simulate detailed changes in driving style. In their present form they are thus not really ideal for measuring changes in these driving conditions and behaviours, *i.e.* the type of modification like to be induced by ITS or eco-driving measures.

Depending on the ITS measures concerned, different levels of accuracy are required. It is necessary to determine whether existing emissions models can make a valid contribution to their assessment. The coherency with the traffic and simulation models and the scales (time and distance) need to be examined carefully. For ITS measures that induce significant changes in the traffic conditions (traffic dynamic) and above all changes in human behaviour, improved or new approaches and models should be envisaged.

CHAPTER 3

Modelling the impacts of ITS on traffic and emissions

Example of an ITS assessment tool

Worldwide, various models have been designed to calculate the impact of ITS measures on traffic flows and emissions. One of them is the 'ITS modeller' which has been used in several EU projects over the last 5 years. By way of example, this model is described below to illustrate some of the features deemed useful for this purpose.

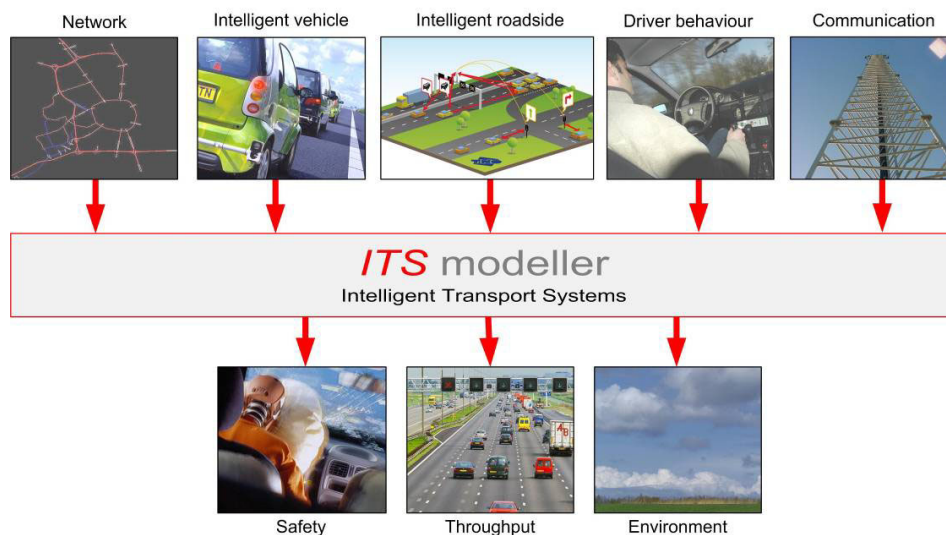

Figure 6: Example of a modelling platform.

Future roadside and in-vehicle cooperative intelligent transport systems require new modelling environments to predict their impact on traffic throughput, traffic safety, noise and emissions.

Roads and vehicles are both getting smarter. At the roadside, traffic management systems are used to ensure safe, efficient and reliable traffic flow on the road network. Vehicles are increasingly being equipped with systems which support a driver's journey efficiently, safely and comfortably. Drivers are well-informed about current and expected traffic conditions, and are able to respond accordingly.

Tools such as the ITS Modeller have the benefit of offering a flexible, innovation-oriented simulation environment which makes it possible to assess the impact at the network and individual levels, and the investigation of deployment issues. They provide a modelling environment that can simulate intelligent transport systems. The ITS Modeller, for example, contains a traffic network where each vehicle, driver and ITS system has its own individual model. Several roadside and in-vehicle systems, as well as cooperative systems, are available as



CHAPTER 3

Modelling the impacts of ITS on traffic and emissions

standard. Tools with these characteristics are therefore well equipped to deal with the innovative ITS solutions of today and the future. New in-car, roadside or cooperative systems and new developments in traffic management can easily be modelled and added to the system because of its flexible modular structure. Innovative ITS solutions can be simulated to assess their impact at any desired level of deployment. This enables the user to assist customers in making decisions about the functions and deployment of ITS systems. The tool can also be used to determine the effects of ITS systems at network level. The modelling environment has several evaluation modules for this purpose.

Some of the elements of the ITS modeller are:

- A versatile route choice module. Route decisions are based on the information that a driver has about the traffic situation as well as driver behaviour.
- Various vehicle models, driver models and models for ITS systems. These need to be state-of-the-art models based on realistic data from driving simulators, vehicle labs (e.g. VeHiL lab) and other sources.
- A message-based communication model that supports advanced message management and various message distribution strategies. This allows users to assess the impact of cooperative systems and the effectiveness of communication strategies
- Evaluation modules for throughput, safety and noise, and calculation of emissions via the emissions model VERSIT+ (referred to earlier).



CHAPTER 4

Data requirements and sources

Overview

The types of traffic model envisaged for CO₂ emissions assessment, and described in the previous Chapter, rely on micro-scale simulation. This, in turn, requires detailed traffic information (data on individual vehicle behaviour, dynamic OD matrices, *etc*). Sophisticated micro-simulation traffic models need additional empirical information, such as acceleration and gear changing behaviour, for the proper validation of the new algorithms.

Particular attention needs to be paid to ensuring consistency between the modelling approaches (*i.e.* traffic and emissions), their underlying assumptions, and the definition of their input and output parameters. Most current emission models assume average driver behaviour, normal engine operation, and average driving conditions, or at best address these through implicit distributions. This means that any ITS application that influences these parameters cannot be properly assessed. In the same way, the notion of speed, acceleration, cruising speed and, more generally, vehicle trajectories or traffic dynamics, can differ considerably according to the different approaches to traffic and emissions modelling. This can lead to inconsistent model chains.

Traffic models are not usually configured in a way which is optimal for emission modelling. Possible differences in definitions, initial aims, time and spatial scales, *etc.*, as well as the underlying assumptions of the models, can lead to inappropriate model chains and erroneous assessment results. For example, traffic assignment models tend to only cover specific periods of the day (*i.e.* peak and inter-peak), and do not have as detailed a system of classification for vehicles as emission models. The harmonisation of traffic and emission models is clearly therefore vital.

Data requirements

Micro-scale traffic data

From the traffic modelling perspective, the data needed for the assessment of ITS measures - and a realistic estimate of traffic emissions - can be divided into two categories: input data and calibration data. With regard to input data, the requirements include items such as network geometry, road capacities, traffic composition, traffic signal data (for urban networks), and traffic demand data (*e.g.* turning counts, origin-destination matrices). Regarding calibration data, the needs include time headway distribution, travel times, queuing information and also acceleration. Such information can be obtained from microscopic traffic data (*i.e.* regarding the behaviour of individual vehicles). This can be partly delivered by inductive loop detectors (ILD). However, new advanced models (those representing driver behaviour, car-following, lane selection, traffic merging, *etc*) need very precise information which can only be obtained using trajectory-based data. Currently, trajectories are normally calculated by processing the images extracted from videotapes from surveillance cameras used to record the traffic on given road sections over specific time periods. The strengths and weaknesses of this type of data are those of CCTV cameras in general. On the other hand, trajectory samples can also be provided



CHAPTER 4

Data requirements and sources

by high resolution probe data recorded directly by equipped vehicles. This brings up some important issues regarding probe vehicles, examined later in this chapter.

For deriving simulated trajectories, a well calibrated and validated traffic simulation tool is necessary. Indeed, microscopic simulation models offer the advantage of generating totally disaggregated data on the relative position of vehicles in a traffic flow. Data of this kind are quite costly to gather from real-life test beds. If such models are correctly calibrated and validated, they can be used to provide trajectory-based data and other microscopic parameters based on real cases. These can then be used to “feed” the emissions indicators, providing consistency in the traffic and emission modelling as regards parameter definition, scales, *etc.*

Reliable dynamic OD matrices

Other important information needed for traffic models, and more generally for the planning and management of traffic operations, is transport demand data. This includes origin-destination (OD) matrices (by mode), turning counts, and routing information. Classically, OD matrices have been based on manual counts or surveys, and have therefore only been available as selective samples. To date, estimates of OD matrices from traffic counts are far from satisfactory. New measurement technologies, permitting continuous and automatic counting of flows, provide data sets which require the development of new analytical tools.

A very different data source for estimating OD matrices is represented by the information collected by probe (instrumented) vehicles. Indeed, if 100% of vehicles on the road were probes, then OD matrices would be known with certainty (assuming there were no limitations on the way the data were gathered and processed). This raises an important question: what is the optimum level of penetration? Or, alternatively, what trade-offs exist between probe vehicle density and the quality of the estimated matrix? In addition, how does the availability of other data, such as link volume counts, influence the quality of the matrix produced?

The dynamic nature of such OD tables (*i.e.* the update interval), which determines the amount of data required to ‘feed’ the model, is clearly dependent on the transport demand profile. A desirable time step is generally considered to be 15 minutes.

CO₂ estimation and traffic data needs

CO₂ emissions may in some cases be less sensitive to traffic dynamics than other pollutants, but the relationship is nevertheless significant (of the same order of magnitude as the sensitivity to vehicle speed). Macroscopic approaches using the average speed, for instance, would therefore be insufficient to reflect the impact of ITS on driver behaviour.

To estimate CO₂ for a single vehicle at a microscopic scale, using for example an instantaneous emission model such as PHEM (see Chapter 3), the necessary data input would be:

- Information on the vehicle (type, fuel, year or registration, mileage, engine power, vehicle weight, *etc.*).
- Instantaneous speed (recorded chronologically), from which the acceleration and dynamic related parameters can be derived.



CHAPTER 4

Data requirements and sources

- The road profile (gradient).
- The engine temperature (which could be however assessed from the speed or the time duration since the start of a trip), to assess the effect of cold starts.
- Whether or not air conditioning is used.
- Other parameters such as the vehicle load (particularly for heavy vehicles).

It should however be borne in mind that such a model assumes average driver behaviour (gear changing, acceleration levels, etc.), which can limit its usefulness for the evaluation of ITS applications that induce significant change in driver behaviour.

Applying the same tools and assuming average traffic conditions (*i.e.* not considering individual vehicles, but using data based on a given national or local fleet composition and structure), and, the following data would be satisfactory:

- the instantaneous speed recording (all other parameters being covered by national assumptions). Such data are, however, rarely available at a large scale.

To estimate CO₂ at the street level (*i.e.* a more macroscopic but still local scale), a ‘traffic situation’ approach, such as that developed in ARTEMIS, would be adequate, provided that information on traffic composition is available, based on national or regional assumptions (this could be improved using local data from video observation, loop information, surveys, *etc.*). In this case, the traffic situation should be described in terms of the percentages of total traffic flow or vehicle km represented by congested (stop-and-go) conditions, saturated flows, free-flow, *etc.*

An ARTEMIS-type approach can be applied to a whole city, providing the road network and traffic is sufficiently well described. This would offer an sufficient level of detail, but requires availability of validated data at the appropriate scale.

For national or regional studies, CO₂ can be estimated:

- By traffic situations based on assumptions regarding the mileage distribution on particular road types and traffic conditions (typical, but representative distributions can be calculated);
- Using the average speed with the same kind of statistics (*i.e.* percentage of traffic by speed class, or at several given speeds). It should be noted that such statistics - although they may appear straightforward - are not in reality easy to establish. It is also likely that the CO₂ impact of ITS applications cannot be satisfactorily assessed at this geographical scale.

Data sources and characteristics

Technological advances in the area of road transport have favoured a great enhancement in the ability to collect detailed traffic data. In addition to traditional roadside sensing equipment, there are innovative approaches, such as microsensing networks, which are for the most part still being tested and not yet fully validated. Numerous on-board sensors are able to offer data



CHAPTER 4

Data requirements and sources

on engine status, driver behaviour, the situation surrounding the vehicle (e.g. neighbouring vehicles), environmental conditions, and so on.

Data collection technologies can be grouped into the three broad categories:

1. Infrastructure-based sensors: inductive loops, closed-circuit television (CCTV), radar, laser scanners, infrared, micro-sensors, wireless sensor networks, *etc.*
2. Vehicle-based sensors: including radar, laser scanners, infrared cameras, etc used for diagnostics purposes or Automatic Driver Assistance Systems (ADAS), as well as data from the CANbus.
3. Cooperative systems: which can combine (fuse) information from the above.

These technologies enable the collection of basic macroscopic traffic characteristics such as flows, speeds, occupancies, and sometimes also path travel time, queues and vehicle trajectories. On-board instrumentation with an access to the OBD (on-board diagnostics) can provide detailed information on the engine and vehicle operation, which is very useful for characterising driving behaviour. The introduction of co-operative systems offers a new and potentially an extremely valuable source of data. These systems are, however, for the most part still at an early stage of development and not yet rigorously tested.

The communication networks used by Cooperative Systems allow subsystem components (e.g. equipped vehicles or road-based devices) to communicate with other subsystem components. This means for instance that data from onboard sensors (including vehicle position, trajectory and transient engine characteristics) and navigation system, as well as the vehicle ID, can be communicated directly to a roadside unit or Traffic Information Centre. The data provided by Cooperative Systems can therefore be very complex, including not only traffic and vehicle-related data but also origin-destination information, segment by segment travel time analysis, *etc.* It does however provide a level of detail of great interest for the validation of emissions models and is consequently a future data source worth investigation.

Data from infrastructure-based sensors

Basic traffic data have, until now, been largely based on conventional road sensors embedded in the pavement. Among the most common are inductive loop detectors used to measure the basic parameters needed by traffic engineers, such as traffic volume or flow rate, occupancy (local density) and spot speed at a given point. Other fixed sensors, such as optical detectors and ultrasonic-based detectors, have been developed for network surveillance.

Sensors with spatial capabilities are increasingly being used to supplement loop detectors: these include CCTV cameras or RTMS (Remote Traffic Microwave Sensor), which are able to make traffic density measurements in addition to the traffic characteristics mentioned above. CCTV is mainly used at present for incident detection and traffic flow assessment, which is undertaken manually by traffic control centre staff. Their use for traffic data collection to support ITS applications is a spin-off benefit. Such cameras can derive high-resolution vehicle trajectory data, thanks to video images processing. Among their strengths are the fact that they offer 100% vehicle coverage. Their main weakness is the short coverage area (under 1 km).



CHAPTER 4

Data requirements and sources

It should also be stressed that the speed measured by a radar, video, or loop detectors is not sufficient to assess CO₂ emissions as these systems provide only time-based distributions of speeds. Spatial integration along a whole trip or road section is needed to assess CO₂ emissions and fuel consumption.

ETC Data

Electronic Toll Collection (ETC), now a mature technology for the payment of motorway tolls, can also be viewed as a potential source of traffic information. ETC data are recorded in two main ways: automatic toll systems in which coin machines or credit cards are used, and Automatic Vehicle Identification (AVI) systems using vehicle-mounted tags (Hensher, 1991; Loukakos, 2006).

Although readily available in theory, the traffic-related information collected is almost never used (see Smith and Benko, 2007). After the application of *ad hoc* cleansing algorithms (cf. de Mouzon *et al.*, 2006), such a source could provide speed or travel time as well as origin-destination matrices for the entry-exit ramps, and total traffic flows, which could be divided into classes to give traffic composition.

Data from vehicle-based sensors (floating car or probe data)

The growing need for real-time data for a wide range of purposes (real-time traffic monitoring, incident detection and route guidance applications), has given importance to a complementary source of data for allowing traffic parameter estimation: the use of floating car data (FCD) or the probe-vehicle data collection technique. This results in a shift in the role of vehicles on the road from a passive to an active one, since they act as ‘mobile sensors’, continuously feeding information about traffic conditions to a Traffic Management Centre (TMC). FCD data are similar to the moving observer method which is used to collect data such as travel time, average speed, delay and stops, acceleration noise and the occurrence of incidents.

Different Automatic Vehicle Identification (AVI) technologies can be used as detection devices:

- Automatic Number Plate Recognition (ANPR).
- Automatic vehicle tag identification (*e.g.* toll tags such as ETC).
- Cell-phone tracking (see *e.g.* Asakura *et al.*, 2000; Ygnace *et al.*, 2001).
- Global Positioning System (GPS).

One can distinguish three main categories of probe data, according to the technology used:

1. Floating Cellular Data: mobile phone cell handover detection (no in-vehicle device required).
2. Floating Car Data (FCD): vehicle with positioning system (GPS) and wireless communication capabilities (*e.g.* GPRS). Extra equipment always has to be installed on the vehicle.

CHAPTER 4

Data requirements and sources

3. Extended Floating Car Data (xFCD): FCD with build-in vehicle sensor data. In addition to FCD equipment, a vehicle bus interface is also needed.

On-board instrumentation with access to OBD (on-board diagnostics) can provide accurate information on fuel consumption as well as engine operation (Perotti *et al.*, 2003) which can be used to derive an estimate of CO₂ emissions.

By itself, the continuous monitoring of vehicle speed (from equipped vehicles or probe cars) can also provide a valid basis for the calculation of CO₂ emissions. Combined with the vehicle position (obtained from GPS information), it can enable an assessment of the influence of the context (local traffic management, traffic conditions, etc.) as well as other impacts (e.g. health effects from pollutants).

Summary of strengths:

- traffic volume by lane
- turning movements
- travel times
- intersection delays
- trajectories
- arterial, freeway, rural road facilities
- other data also available (*e.g.* xFCD can deliver weather or signalling (turning) information, engine operation, fuel consumption, and CO₂).

Main weaknesses:

- Only one is vehicle tracked
- Data quality is subject to level of fleet penetration
- Data privacy issues may be raised by the use of such data.

With regard to the use of probe information for estimating CO₂ emissions, existing initiatives in Europe, Australia and elsewhere show potential. It is, however, important to be aware that the use of operational data from private vehicles (when individual identification is possible) requires permission from the vehicle owner. In the case of private drivers this is clearly a serious drawback.

It therefore seems more practical, at least under current conditions, to gather probe data from fleet vehicles (bus, coaches, trucks, taxis, *etc.*). A growing number of fleet managers appear willing to install the equipment necessary to enable the monitoring of vehicle behaviour to enable the fuel/energy consumption estimates as well as environmental information, including CO₂ modelling. It would be of great interest to have such information for hybrid and electric vehicles as well as conventional fuels.

The following table summarises characteristics of the major traffic data sources.

CHAPTER 4

Data requirements and sources

Table 4: Main existing sources of traffic data¹²

Traffic data type	Data collection technique	Traffic characteristics	Key applications
Aggregated data from loop detectors (e.g. aggregation period 6 min)	Loop detectors, ultrasonic detectors	Volume, occupancy, spot speed (temporal mean speed)	Incident management decision support, activation of dynamic TMS, traffic performance indicators (travel time), macroscopic traffic model calibration
Data on individual vehicles	Loop detectors, ultrasonic detectors Probes	Speed, occupancy, headway	Same than above + microscopic traffic model calibration, risk-based indicators
	Unidentified FCD data and toll stamps data	Speed, travel time	Travel time (TT) estimation, commercial vehicle applications, reference TT for validation
	Identified FCD and CCTV cameras	Speed, travel time, density, trajectories	Traffic performance indicators, congestion proxy, risk-based indicators, microscopic traffic model calibration/validation

Summary of considerations regarding CO₂ emission estimates

With regard to the use of speed measurements for estimating CO₂ emissions:

- The speed detected by radar systems, video, or loops is not satisfactory for assessing CO₂ emissions as it does not take into account stops, acceleration/deceleration, and other transient driving behaviour. Integrated speed information is necessary (over a trip, over a certain distance, *etc.*)
- Speed measurements continuously measured or monitored by vehicles, probe cars, *etc.* are a useful data source for estimating CO₂ emissions.
- It is better if it is localised (i.e. combined with GPS information) to assess the influence of the context, and to assess the local impacts (for local air pollutants, not for CO₂)
- The Field Operational Tests supported by the European Commission, such as the FOT-NET initiative (<http://www.fot-net.eu>) are of great interest in this respect.

Field Operational Tests (FOT) as data sources

One of the primary aims of Field Operational Tests (FOT) is the assessment of the behaviour of road users in traffic environments equipped with new ICT-based systems. They represent another valuable source of information as they involve data collection in real world settings (cf. SmartWay in Japan, IVI in USA). Experimentation has demonstrated the potential of vehicle-

¹² Most of the models listed also address other types of vehicle, such as heavy goods vehicles and buses.



CHAPTER 4

Data requirements and sources

based sensors for analysing driver behaviour (Younglove *et al.*, 1998; De Fries *et al.*, 1992; André *et al.*, 1991), characterising fuel consumption and emissions (Effa *et al.*, 1993; Austin *et al.*, 1993; André, 2004), as well as vehicle and engine operation (Johnson *et al.*, 1975; Pela *et al.*, 1998; Green *et al.*, 2002), or designing mission profiles (André, 1999). Until now, FOTs have mostly involved passenger cars, but significant work is now being carried out with commercial and heavy-duty vehicles (André *et al.*, 1997, 2005) through the use of electronic engine control units (Huai *et al.*, 2006).

The operational data from FOTs, collected for sufficiently large fleets of vehicles, deliver not only information on the prevailing traffic conditions, but also valuable information on the impact of ICT-based systems (including ADAS and cooperative systems). This, as well as data on driver behaviour, is of great interest for the development of methodologies for assessing energy consumption and CO₂ emissions of vehicles. Among such tests is a study undertaken in the US with extensive on-board instrumentation, including video and radar (Neale *et al.*, 2005), and large-scale mobility studies using data loggers and GPS (Wolf *et al.*, 2000; Scöfnelder *et al.*, 2005). Several pilot experiments have also been conducted to implement integrated solutions for traffic management through advanced vehicles and telematic tools (probe vehicles providing real-time information on the traffic, traffic control and management, see the ATENA project, Gortan *et al.*, 2001; Günemann *et al.*, 2004). Large scale FOTs are currently being promoted by the European Commission.

The necessary vehicle instrumentation can now be quite simple and provided at low cost (use of the OBD information, GPS, transmission through GSM/GPRS, Perotti *et al.*, 2003). “Equipped” cities, as envisaged by Virginia Tech (<http://www.vtti.vt.edu>) or Leeds University (<http://www.its.leeds.ac.uk/facilities/icity>), also constitute a promising way of combining traffic and vehicle-based information through a large-scale deployment of instrumentation, and hence also for the assessment of ITS applications.

Other considerations

Data quality

As new ITS applications are being deployed, data quality issues are becoming more and more critical. Finding ways of ensuring high data quality is therefore a critical issue, as it will also affect the consistency and validity of model-based estimates of CO₂ emissions.

With regard to the traditional data sources, the quality issues are relatively well known. Data provided by inductive loops, for instance, have various sources of error. The case of complete sensor failure due to general malfunctions (i.e. no data or clearly wrong data) can easily be identified using statistical tools. The most difficult case concerns sensor drift (i.e. small but systematic errors due to improper adjustment) since the resulting data are still plausible and errors are hard to identify (El Faouzi *et al.*, 2008). The reliability of data from the more recent applications, and especially cooperatives systems, is, as yet, less well documented.

Measuring data quality requires an understanding of how exactly the data will be used. Besides accuracy and completeness (availability), other characteristics may be equally important:



CHAPTER 4

Data requirements and sources

validity, timeliness, coverage, and accessibility (usability). The impact and nature of data quality is therefore highly application-dependant, and has to be judged with respect to the objectives of the model concerned.

Data fusion

The data needs of traffic operators and managers have, until now, generally been met through conventional measurement techniques, and have involved a single or small number of sensing systems. However, in the present context, where highly accurate information is needed (see FHA, 1996; El Faouzi and Lesort, 1995), it is likely that a number of data sources may need to be integrated to provide information of sufficient quality. In fact, as explained above, a wide spectrum of different data sources can be potentially used for building the models required for assessing CO₂ emissions (El Faouzi, 1997, 2003, 2004, 2006). This suggests that new data fusion techniques will possibly have to be developed.

Need for a data warehouse

In order to facilitate the ‘extraction’ of information coming from heterogeneous data sources (e.g. via data mining or data fusion techniques), it could be very useful to implement a data base specifically conceived for this purpose. More precisely, a *data warehouse* would offer an extremely valuable basis for evaluating ITS applications. Such a warehouse could serve as a repository of integrated information available for queries and analysis.

Among the benefits of a data warehouse (Humphshires, 1999) is the fact that it could:

- facilitate reporting as well as analysis
- provide well organised historical information
- serve as an adaptive and resilient source of information, and finally
- offer a good basis for decision making.

Significant efforts to initiate the development of a comprehensive Traffic Data Warehouse with an international dimension have already been made by the University of Tokyo (Kuwahara *et al.*, 2008).

Data ownership, protection and privacy

The availability of many of the data items described in this Chapter relies in many cases on having open access to databases used for other purposes. This raises the major issue of data ownership. For a warehouse to be set up, strategic partnerships would need to be forged between transport managers and road traffic operators. In other words, a model for public-private cooperation would be required for the development and deployment of a large traffic data platform.

Another critical issue to be resolved concerns data protection and privacy. Access to vehicle registration data (especially when cross-border), involves different national legislation. Indeed, location data (from GPS-enabled mobile devices, phone tracking, probes etc) as well as



CHAPTER 4

Data requirements and sources

vehicle registration data are very sensitive and have to be recorded anonymously (i.e. with appropriate privacy filters). This concern is linked to the EU Data Protection Directive¹³, and more precisely the Article 29 Working Party Data Protection.

¹³ http://ec.europa.eu/justice_home/fsj/privacy/workinggroup/index_en.htm



CHAPTER 5

Issues to be resolved

This Chapter summarises the main issues raised in the preceding Chapters. It also attempts to identify the gaps between what is currently available and what is required (in terms of tools, techniques and data) for the assessment of the impact of ITS on CO₂ emissions. It begins however by reflecting on the main scope and purpose of the common methodology.

The scope of the methodology

A fundamental issue regards the principal use foreseen for the proposed methodology. While the basic aim is obviously to establish a standardised approach which will give validity to international comparisons, the methodology could be used in several different ways, each with different implications.

Among the possible uses of a common methodology are:

- To provide data which makes it possible to weigh up the costs and benefits of a proposed ITS strategy before its implementation (e.g. in particular, the trade-off between safety, efficiency and environmental factors);
- To provide a standardised way of quantifying the reduction in CO₂ emissions attributable to a specific ITS implementation (already installed);
- To enable the assignment of a “green class” to ITS products (e.g. Class A, B, C etc) according to an independent validation of its performance in reducing CO₂ emissions;
- To provide a methodology for assessing bundles of applications implemented in a given context, e.g. on motorways, in urban areas;
- To provide a method for undertaking a “green audit” of a whole city or region (encompassing all ITS strategies applied in the area concerned);
- To provide data to enable the fine-tuning of an application during installation.

Associated issues

- In proposing a common methodology it will be essential to take into account **cost-related and institutional issues** as well as technical questions. Much of the data required by the suggested models can be expensive to obtain and/or raise data protection concerns.
- Ways will need to be found of assessing the combined impact of different ITS applications operating in the same geographical area (i.e. to establish whether the effect on CO₂ emissions is cumulative or not).
- Due to the trade-offs between network efficiency, safety and environmental factors, it is likely that green ITS measures will be activated only when given thresholds are exceeded (i.e. not on a permanent basis). How can this dynamic operational mode be taken into account in impact measurements?



CHAPTER 5

Issues to be resolved

Issues regarding traffic models

Simulation seeks to provide an accurate representation of (potential) real-world systems. Current technology needs careful calibration to be able to provide reliable data. This means that sets of calibration data must be available to verify or tune simulations to different circumstances. Such circumstances include environmental conditions (weather, road surface) and details of driving behaviour.

Probably the most challenging factor in simulation is the issue of human behaviour. Current models do not always take into account the type of driver behaviour relevant to CO₂ emissions and/or energy consumption, or consider only a few parameters. It is necessary to establish to what extent it is feasible to develop validated driver behaviour models taking into account:

- Drivers' responses to traffic signals, driving advice, *etc.*
- Regional differences in driving behaviour.
- Variable external conditions (*e.g.* the weather, road condition, visibility).
- A representative distribution of driving behaviours as well as their evolution or sensitivity to typical ITS measures.
- Interaction between individual vehicle behaviour and traffic flows.

When traffic management strategies interact with driver behaviour, an accurate model of the traffic management strategy is important. The following are therefore needed/useful:

- The actual traffic control strategies operating in the simulation environment. This should include direct interaction with the simulated driver or vehicle behaviour when the traffic control strategy uses co-operative technology.
- An interface (preferably universal for all simulation environments) between simulation models and simulated traffic control strategies.

It is necessary to have transport demand models which consider not only modal choices, but dynamic route planning and trip timing.

Issues regarding emission models

Emission (and especially instantaneous emission) models are continuously being improved. Current models do not however for the most part provide satisfactory treatment of:

- the vehicle (engine) response to the details of driver behaviour;
- microscopic approaches validated for the assessment of ITS applications;
- appropriate scales and parameters for combination with the traffic models.

Appropriate models are therefore needed, taking into account the driving behaviour and conditions at the required scale (consistent with traffic models). Such models should be based on real-world driving data with a sufficient range of driving conditions and behaviours.



CHAPTER 5

Issues to be resolved

To set up a representative simulation it is necessary to know the mix of vehicles that constitute the simulated demand. For this it is useful to be able to:

- Derive vehicle characteristics from measured data. The most accurate way is to gather vehicle registration data and retrieve vehicles characteristics from the various European vehicle registration databases.
- Compile a database with representative vehicle mixes for the situations to be simulated. This database should enable predictions to be made for future vehicle mixes (in which hybrid and electric vehicles will play a bigger part).

Issues regarding data needs and databases

From the previous paragraphs it should be clear that the use of real-life data is extremely important. There are, however, large differences between Member States in the availability of data. Therefore the following are needed:

- An analysis of the data needs for accurate simulations that include situation- and human behaviour - sensitive emission models.
- An analysis of available traffic databases (public and private) in the various Member States.
- Access tools for the various traffic databases (possibly with a conversion to a standardised format).
- Real-world driving data enabling the characterisation of the influence of detailed traffic conditions and human driving behaviours on emissions, as well as the development of appropriate emission models.

There is also a lack of basic data for setting up accurate simulations:

- Information on roads (curvature, slopes, traffic calming measures).
- Information on rules and regulations in the network (*e.g.* speed limits)

Specific modes can have a considerable impact on the results of the simulations, therefore (easy access to) the following data would be useful:

- Public Transport schedules: information systems used by public transport operators to maintain their schedules could be useful a source of data.
- Freight movements: data on commercial vehicle movements generated by logistic systems could be extremely valuable, but such information is normally confidential. Acceptable ways would need to be found for gaining access.

The optimisation of mobility from the environmental point of view is subject to intensive study and experimentation. Large scale tests (*e.g.* FOTs) can produce valuable data. This data should be fed back into traffic databases and made available for future work.

CHAPTER 6

Recommendations for joint discussion

Preliminary Recommendations

The following points summarise the findings reached by the EC-METI Task Force after the first stage of work (analysis of the state of the art in Europe). They consist of some preliminary recommendations for joint discussion in the first workshop.

1. Identifying the Core Green ITS applications

It is felt that the Joint Task Force should seek to reach an agreed definition of what is meant by 'Green ITS' and that the core applications supporting this should be identified.

- The following six categories are proposed by the European Task Force:
 - Traffic Management and Control Systems
 - Demand and Access Management Systems
 - Navigation and Travel Information Systems
 - Driver Behaviour Change and Eco-driving
 - Logistics and Fleet Management Systems
 - Safety systems
- (A list of the applications included in each category can be found in Annex 1).
- In order to establish appropriate methods for each context, the ITS applications could also be associated with the road environment or geographical areas targeted, e.g.:
 - Urban areas
 - Motorways
 - Regional/national networks
- The appropriate scale for the assessment of each ITS application should be agreed in order to include network level effects.

2. Agreeing the fundamental elements of the common assessment methodology

Agreement should be sought on the purpose, the scope and the basic building blocks of the common methodology.

- In Europe four core elements have been identified:
 - Traffic Simulation Models (including communications simulation models)
 - Emission models
 - Probe information
 - Traffic databases
- The methodology should cover the assessment of CO₂ reductions associated with:
 - Changes in transport demand
 - Changes in the behaviour and routing of traffic on the road network
 - Changes in the driving characteristics of single vehicles (eco-driving effect)



CHAPTER 6

Recommendations for joint discussion

- With regard to the main purpose foreseen for the methodology, the priorities should be indicated from the list of possible objectives listed in Chapter 5.

3. Defining a Roadmap for developing the required modelling technologies

The review reported in Chapter 3 indicates that while there are several simulation models which have useful features for supporting the evaluation of the impact of ITS applications on fuel efficiency and emissions, they also have serious shortcomings. The gaps identified in the current simulation technology and other issues which need to be addressed for the development road map are listed below:

- Development of new ‘driving cycle’ models, taking into account driving behaviour relevant to CO₂ emissions, *e.g.* responses to traffic signals, acceleration patterns, gear changes, eco-driving advice, *etc.* It is proposed that such cycles could be correlated with given traffic flow categories, *e.g.* quiet, free-flow, busy, congested.
- Decide whether and how such models should take into account regional differences in behaviour and external conditions (*e.g.* weather, road conditions, visibility, *etc.*).
- Agree on the vehicle categories to be used for the above.
- Agree on standard tools for calibration/validation of the simulation models.
- Agree on standardised (open) interfaces between the different modules (*e.g.* between emission models and micro simulation models).
- Establish the potential of Cooperative Systems to provide data input for simulation models. Identify the most promising types of data source.

4. Databases and probe information

On the basis of the analysis made in Chapter 4, it is clear that the clear definition of data needs and availability is of major importance. The following actions are therefore recommended:

- Clarify the implications of Data Protection and Privacy legislation in both Europe and Japan in relation to the collection of data for modelling and validation, especially with regard to probe information.
- Make a detailed analysis of the availability of relevant traffic databases (public and private) in the various Member States of Europe, and in Japan.
- Develop a common access tool for traffic databases in EU and Japan.
- Develop of a standard database for calibration and validation purposes.
- Agree on common parameters for information used to characterise roads (curvature, slopes, traffic calming measures).
- Agree on the most appropriate approaches to the collection of probe vehicle data for use in validating traffic models and emissions monitoring systems.



CHAPTER 6

Recommendations for joint discussion

- Investigate the potential of using instrumented fleet vehicles (buses, taxis, public service vehicles, etc) as probe vehicles.
- Compile a common database with representative vehicle mixes for use in simulations. This database should enable predictions to be made for future vehicle mixes (in which hybrid and electric vehicles will play a bigger part).



Acronym	Description
ANPR	Automatic number plate recognition
ATIS	Advanced Traveller Information System
AVI	Automatic vehicle identification
CCTV	Closed-circuit television
CO	Carbon monoxide
CO ₂	Carbon dioxide
Ecodriving	A style of driving aimed at optimising fuel consumption
ETC	Electronic toll collection
FCD	Floating car data
FOT	Field operational tests
GPS/GPRS	Global Positioning System/General Packet Radio Services
ICT	Information and Communications Technologies
ILD	Inductive loop detectors
ITS	Intelligent Transport Systems. A sub-division of ICT
METI	Japanese Ministry of Economy, Trade and Industry
NO _x	Total oxides of nitrogen
OD	Origin – Destination
PM	Particulate matter
PT	Public transport
TMC	Traffic Management Centre
TMS	Traffic management system
TT	Travel time
UTC	Urban Traffic Control



VOC	Volatile organic compound
V2I	Vehicle to Infrastructure
V2V	Vehicle to Vehicle
V2X	Vehicle to X

ANNEX I

ANNEX I

Table 1 - List of ITS Applications, their potential for CO2 reduction and simulation type

CATEGORY	SYSTEM	SCALE/ ROAD TYPE	BRIEF DESCRIPTION	ECO FRIENDLY VERSION?	CO-OPERATIVE ENHANCEMENTS?	SIMULATION
NAVIGATION AND TRAVEL INFORMATION	On-board navigation systems	WN Regional /national	Routing recommendations usually based on calculation of fastest route to set destination.	Yes, when routing takes into account aspects like the expected speed profile. Impact potential: low	Easier to implement.	Simulation type: trip-motives
	'Green' enhanced navigation services	WN City/ regional/ national	Routing recommendations taking into account environmental status, network characteristics and in some cases also Can bus data.	Advanced systems which are connected to CAN bus and which consider network features can offer 'eco-routing' service. Impact potential: low	Easier to implement.	Simulation type: trip-motives
	On trip routing via mobile devices	WN City/ regional	Route recommendations which can be received during trip on PDA or mobile phone.	Possible shift in modal split if multimodal information. Impact potential: low	Easier to implement.	Simulation type: trip-motives

CATEGORY	SYSTEM	SCALE/ ROAD TYPE	BRIEF DESCRIPTION	ECO FRIENDLY VERSION?	CO-OPERATIVE ENHANCEMENTS?	SIMULATION
	Dynamic on-trip routing	WN City/ regional	Route recommendations which can be received during trip on PDA or mobile phone taking into account real-time traffic status and/or environmental conditions.	Routing according to green criteria. Possible shift in modal split if multimodal information for PT passengers. Impact potential: moderate	Easier to implement.	Simulation type: trip-motives
	Web-based pre-trip information services	WN City/ regional/ national	Route planning for given destination consulted before trip.	Possible shift in modal split if multimodal information available. Impact potential: low		Simulation type: trip-motives
TRAFFIC MANAGEMENT AND CONTROL	Isolated controlled intersections	Urban Inter-urban	Generally used for safety. The specifics of the control are different from place to place.	Can be optimised for stop reduction and/or for stop reduction for specific vehicle types (trucks, public transport, but also bicycles). Impact potential: moderate to high <i>local</i> effect possible, depending on existing situation.	Improved control. Speed advice. Smoother behaviour.	Details are important here, resulting in labour intensive simulation. Validation can be local and detailed (at a cost). Validation is difficult to generalise to other situations. Simulation type: fine-grained

CATEGORY	SYSTEM	SCALE/ ROAD TYPE	BRIEF DESCRIPTION	ECO FRIENDLY VERSION?	CO-OPERATIVE ENHANCEMENTS?	SIMULATION
	Plan based control, including 'Green wave' strategy	Urban Inter-urban	Synchronisation of lights to favour traffic flows on specific routes. Optimisation criteria can be overall minimum delay or minimal number of stops.	Easy to implement version with minimum stops. Optionally specific measures for high-impact vehicles. Impact potential: moderate, depending on existing situation.	Speed advice. Smoother behaviour.	The control is generally simple (with exceptions), so the effort for building a simulation is limited. Validation could be done in a few typical situations. Probably giving transferable results (need to be 'meta-validated'). Simulation type: stops, speed, class
	Traffic-adaptive Urban Traffic Control	Urban	UTC system which is able to measure and forecast queue length and adjust phases to optimise efficiency (not fixed plan).	In its basic version it minimises overall delay, which can also have a positive 'eco' impact. Impact potential: moderate		The specification of the control is generally simple, which makes setting up a simulation easy. Behaviour, however, is very flexible which makes simulation and validation time consuming. Results are probably difficult to transfer? Simulation type: stops, speed, class

CATEGORY	SYSTEM	SCALE/ ROAD TYPE	BRIEF DESCRIPTION	ECO FRIENDLY VERSION?	CO-OPERATIVE ENHANCEMENTS?	SIMULATION
	Adaptive UTC with PT priority	Urban	UTC system which is able to identify position of public transport and give buses/trams priority at intersections.	Can be tuned to give priority to vehicles e.g. buses, to reduce stops. Impact potential: moderate to high	Improved control. Speed advice. Smoother behaviour. Better monitoring.	The specification of the control is more complex, which makes setting up a simulation less easy. Behaviour is very flexible which makes simulation and validation time consuming. Results are probably difficult to transfer? Simulation type: fine-grained
	Adaptive UTC with vehicle weighting	Urban	Application using cooperative systems to identify individual vehicles in traffic flow and 'negotiation' priority at intersections (e.g. public transport vehicles, HGV).	Eco-version involves regulating high level strategy to minimise stopping times over whole system Impact potential: high. depending on existing situation.	Improved control. Speed advice. Smoother behaviour.	The specification of the control is complex, which makes setting up a simulation time consuming. Behaviour is very flexible which makes simulation and validation time consuming. Results are probably difficult to transfer? Simulation type: fine-grained
	Ramp metering	M'way	Traffic lights to manage influx of vehicles to ring road or motorway system.	Possible to regulate flows to promote optimum m/w speed (balanced against waiting time). Impact potential: moderate	Improved control. Speed advice. Smoother behaviour of traffic flows.	Easy to simulate. Validation could be limited to a number of typical scenarios. Results would be transferable. Simulation type: fine-grained

CATEGORY	SYSTEM	SCALE/ ROAD TYPE	BRIEF DESCRIPTION	ECO FRIENDLY VERSION?	CO-OPERATIVE ENHANCEMENTS?	SIMULATION
	Dynamic speed limits	M'way Inter- Urban	Traffic regulation to impose a given speed (on motorways) according to real-time flow conditions.	Could have criteria for energy-consumption in addition to flow considerations. Impact potential: moderate	Smoother traffic flow behaviour.	Easy to simulate. Validation could be limited to a number of typical scenarios. Results would be transferable. Simulation type: stops, speed, class
DEMAND AND ACCESS MANAGEMENT	EFC (Electronic Fee Collection)	M'way	Automatic fee collection at road barriers.	Shift in modal split. Possible fuel reduction as stops at toll booth avoided. Impact potential: low to moderate	Easier to implement.	Macroscopic modelling with strong behavioural aspects. Validation only possible in 'real' systems. Simulation type: trip-motives
	Cordon pricing/Congestion	Urban	Form of fee collection within a pre-defined zone Congestion pricing	Shift in modal split. Impact potential: moderate to high	Easier to implement.	Macroscopic modelling with strong behavioural aspects. Validation only possible in 'real' systems. Simulation type: trip-motives
	'Carbon credit' scheme	WN City/ regional/ national	Management of a system based on carbon assessment of trips, which can be bought and sold.	Overall capping of carbon production possible in theory. Not so easy to manage? Impact potential: moderate to high	Easier to implement.	Simulation type: trip-motives

CATEGORY	SYSTEM	SCALE/ ROAD TYPE	BRIEF DESCRIPTION	ECO FRIENDLY VERSION?	CO-OPERATIVE ENHANCEMENTS?	SIMULATION
	Restricted traffic zones (e.g. low pollution, low noise areas)	Urban	Entry restrictions to given area. Criteria can be vehicle type, socio-economic necessity, credits.	Avoidance of traffic in vulnerable areas. Possibly overall traffic reduction. Impact potential: moderate	Makes implementation a lot easier.	Simulation type: trip-motives
	Pay-as-you-drive strategy	WN City/ regional/ national	Onboard black box to charge according to infrastructure use. Can potentially be made very complex, to include dynamic congestion charge functionality, additional fees for environmental zones, time of day etc.	Yes, if weighted in favour of non polluting behaviour. Shift in modal split. Impact potential: moderate	Easier to implement.	Simulation needs to include a behavioural model. Probably difficult to validate? Simulation type: trip-motives
DRIVER BEHAVIOUR CHANGE AND ECO-DRIVING	Promotion of an energy-efficient style of driving	WN City/ regional/ national	Recommendations e.g. on Internet, PC or via onboard displays to encourage energy saving driving behaviour.	Yes, due to improved eco-conscious driving style. Impact potential: moderate	Makes it possible to support by giving information on the infrastructure (predicted state of control systems, speed advice, turns, upcoming ramps, etc.)	Needs detailed behavioural model for simulation. Validation through logging of individual trips. Simulation type: fine-grained

CATEGORY	SYSTEM	SCALE/ ROAD TYPE	BRIEF DESCRIPTION	ECO FRIENDLY VERSION?	CO-OPERATIVE ENHANCEMENTS?	SIMULATION
	On-board assistance units to promote eco-driving	WN City/ regional/ national	Real-time vehicle energy-efficiency data through onboard unit attached to CANbus to promote eco-driving.	Yes. Designed to reduce CO2 emissions. Impact potential: moderate		Simulation type: fine-grained
LOGISTICS AND FLEET MANAGEMENT (Commercial and Public Transport fleets)	Automated Vehicle Management AVM + AVL systems	Urban Inter-urban	Assisting individual professional vehicles on their trips, for efficiency and safety.	Yes, when efficiency considerations include eco-criteria. Impact potential: moderate	Easier to implement.	Simulation type: stops, speed, class
	Commercial Fleet Management services	WN Regional / national /inter-national	Supporting logistics of commercial fleets.	Fleet scheduling can include eco-criteria. Impact potential: moderate	Easier to implement.	Simulation type: stops, speed, class
	Parking/Loading /Delivery Management	Urban	Allocation of parking spaces and loading/unloading areas in busy urban environments.	The functionality avoids unnecessary movements in busy areas. Impact potential: moderate	The nature of the system is cooperative. Standard cooperative services will make it easier and cheaper to implement.	Simulation type: fine-grained

CATEGORY	SYSTEM	SCALE/ ROAD TYPE	BRIEF DESCRIPTION	ECO FRIENDLY VERSION?	CO-OPERATIVE ENHANCEMENTS?	SIMULATION
	Demand-responsive systems for public transport	Urban Inter-urban	Systems for organising a flexible use of vehicles and vehicle-types on flexible routes based on actual demand.	Routing and vehicle choice can use eco-criteria. Impact potential : moderate to high	Easier to implement.	Simulation type: trip-motives
	Public transport priority and regularity	Urban Inter-urban	Priority systems directly lead to less stops. Service regularity leads to smoother trips. These systems indirectly make public transport more attractive, affecting the modal split.	Essentially eco-friendly. Directly through stop reduction indirectly through modal split shift. Impact potential : moderate to high	Easier to implement.	Simulation type: fine-grained
SAFETY AND EMERGENCY SYSTEMS	On-board accident prevention systems	WN Regional / national /inter-national	Congestion is often caused by incidents. A reduction of incidents gives less congestion.	Congestion causes stop-and-go traffic. Impact potential : moderate to high	Easier to implement.	Simulation type: stops, speed, class
	Infrastructure based incident prevention systems	WN Regional /national /inter-national	By prevention incidents, congestion is reduced. Can be combined with on-board accident prevention.	Impact potential : moderate to high	The combination of infrastructure based systems and on-board systems is especially strong (SAFESPOT)	Simulation type: stops, speed, class



CATEGORY	SYSTEM	SCALE/ ROAD TYPE	BRIEF DESCRIPTION	ECO FRIENDLY VERSION?	CO-OPERATIVE ENHANCEMENTS?	SIMULATION
	Incident management systems	WN	Systems organise the response to incidents (emergency vehicles, clearing of the incident, taking measures to avoid secondary incident)	System reduces congestion by quicker clearance of incident location and avoidance of secondary congestion. Impact potential : moderate to high	Faster response, easier/faster dissemination of relevant incident information.	Simulation type: stops, speed, class

Legend: Scale (of transport network) or road type affected: Urban = Urban roads, M'way = Motorways, Inter-urban = Interurban road network, WN = whole (road) network. NB. The 'Impact potential' represents an expected effect based on 'rule of thumb' assumptions and not on measurement of CO2 impacts in rigorous field tests.

Applications

- (1) **Kompfner P, Reinhardt W and Members of the Working Group ICT for Clean and Efficient Mobility (2008)** ICT for Clean and Efficient Mobility – Final Report, Brussels, November 2008.

Emission Modelling Approaches:

- (2) **Atjay D and Weilenmann M (2004)**. Compensation of the exhaust gas transport dynamics for accurate instantaneous emission measurement. *Environmental Science and Technology*. Vol. 38 (19), pp. 5141-5148.
- (3) **Barlow T J, Hickman A J and Boulter P G (2001)**. Exhaust emission factors 2000: Database and emission factors. Project Report PR/SE/230/00. TRL Limited, Crowthorne.
- (4) **Barth M, An F, Younglove T, Scora G, Levine C, Ross M and Wenzel T (2001)**. Comprehensive modal emissions model (CMEM), version 2.02: User's Guide. University of California Riverside Center for Environmental Research and Technology.
- (5) **Boulter P G, McCrae I S and Barlow T J (2007)**. A review of instantaneous emission models for road vehicles. TRL report PPR267. TRL Limited, Wokingham.
- (6) **Boulter P G and McCrae I S (editors) (2009)**. ARTEMIS: Assessment and reliability of transport emission models and inventory systems – Final Report. Deliverable 15. Commission Européenne. TRL Report PPR350, TRL Limited, Wokingham.
- (7) **Barlow T J, Boulter P G and McCrae I S (2007)**. An evaluation of instantaneous emission models. TRL report PPR268. TRL Limited, Wokingham.
- (8) **Coelho M C, Fariasa T L and Roupail N M (2005)**. A methodology for modelling and measuring traffic and emission performance of speed control traffic signals. *Atmospheric Environment*. Vol. 39, pp. 2367–2376.
- (9) **Dowling R, Skabardonis A and Alexiadis V (2004)**. Traffic analysis toolbox volume III: Guidelines for applying traffic microsimulation modelling software. Dowling Associates. Report number FHWA-HRT-04-040. Federal Highway Administration, Washington.
- (10) **Ericsson E (2000)**. Variability in urban driving patterns. *Transportation Research*. Part D 5, pp. 337-354.
- (11) **Frey H, Roupail N, Unal A and Colyar J (2001)**. Emission reduction through better traffic management: an empirical evaluation based upon on-road measurements. North Carolina Department of Transportation, Report No. FHWA/NC/2002-001, USA.
- (12) <http://www.ncdot.org/planning/development/research/1999-08.html>
- (13) **Gkatzoflias D, Kouridis, Ntziachristos L and Samaras Z (2007)**. COPERT IV. Computer program to calculate emissions from road transport. User Manual (version 5.0). Published by ETC-ACC (European Topic Centre on Air and Climate Change).
- (14) **Hassounah, M I and Miller E J (1995)**. Modelling air pollution from road traffic: a review. *Traffic Engineering and Control*. Vol. 35 (9), pp 510-514.
- (15) **Hausberger S (1998)**. Planung und Koordination zur Aktualisierung der Emissionsfaktoren für Schwere Nutzfahrzeuge; Institut für Verbrennungskraftmaschinen und Thermodynamik der TU-Graz. Technical University of Graz, Austria.
- (16) **Highways Agency, Scottish Executive Development Department, Welsh Assembly Government and the Department for Regional Development Northern Ireland (2007)**. Design Manual for Roads and Bridges, Volume 11, Section 3, Part 1, Air Quality, Highways Agency, Scottish Industry Department, The Welsh office and the Department of Environment for Northern Ireland, Stationary Office London.
- (17) **W-T, Tong H-Y and Cheung C-S (2005)**. A modal approach to vehicular emissions and fuel consumption model development. *Journal of the Air and Waste Management Association*. Vol. 55, pp. 1431-1440.
- (18) **INFRAS (2004)**. Handbook of Emission Factors for Road Transport, Version 2.1. INFRAS, Berne, Switzerland, February 2004.
- (19) **Kean A J, Harley R A and Kendall G R (2003)**. Effects of vehicle speed and engine load on motor vehicle emissions. *Environmental Science and Technology*. Vol. 37, No. 17, pp. 3739-3746.
- (20) **Koupal J, Landman L, Nam E, Warila J, Scarbro C, Glover E and Giannelli R (2005)**. MOVES2004 energy and emission inputs. US Environmental Protection Agency, Office of Transportation and Air Quality. Report ERPA420-P-003. USEPA.
- (21) **Leung Y C and Williams D J (2000)**. Modelling of motor vehicle fuel consumption and emissions using a power-based model. *Environment Monitoring and Assessment*. Vol. 65, pp. 21-29.
- (22) **Negrenti E (1998)**. The 'corrected-average-speed' approach in ENEA's TEE model: an innovative solution for the evaluation of the energetic and environmental impacts of urban transport policies. 19th ARRB Transport Research Limited Conference, Sydney, Australia.

References

- (23) **Osses M, Henriquez A and Trivino R (2002)**. Positive mean acceleration for the determination of traffic emissions. Paper presented at the conference 'Transport and Air Pollution', Graz, Austria, 19-21 June 2002.
- (24) **Rexeis M, Hausberger S, Riemersma I, Tartakovsky L, Zvirin Y and Erwin C (2005)**. Heavy-duty vehicle emissions. Final Report of WP 400 in ARTEMIS (Assessment and Reliability of Transport Emission Models and Inventory Systems); DGTREN Contract 1999-RD.10429; Report no. I 02/2005/Hb 20/2000 1680. University of Technology, Graz.
- (25) **Smit R, Smokers R and Schoen E (2005)**. VERSIT+ LD: Development of a new emission factor model for passenger cars linking real-world emissions to driving cycle characteristics. Proceedings of 14th International Symposium on Transport and Air Pollution Graz, Austria, 1-3 June.
- (26) **Sturm P J, Boulter P G, de Haan P, Joumard R, Hausberger S, Hickman J, Keller M, Niederle W, Ntziachristos L, Reiter C, Samaras Z, Schinagl G, Schweizer T and Pischinger R (1998)**. Instantaneous emission data and their use in estimating passenger car emissions. Deliverable 6 of the MEET project. VKM-THD Vol. 94, Technical University of Graz, Graz, Austria.
- (27) **TfL (2003)**. Micro-simulation modelling guidance note for TfL. July 2003. Transport for London Street Management, London.

Probe Information and Traffic Database

- (1) **Johnson T M, Formenti D L, Gray R F, Peterson W C (1995)**. Measurement of motor vehicle operation pertinent to fuel economy. SAE Paper 750003, 32p.
- (2) **DeFries T H and Kishan S (1992)**. Light-duty vehicle driving behaviour: Private Vehicle Instrumentation. Radian Corp., Austin (Texas). Report DCN92-254-036-90-04, ~400p.
- (3) **André M (1991)**. In Actual Use Car Testing: 70,000 Kilometers and 10,000 Trips by 55 French Cars under Real Conditions. SAE, Technical Paper Series N°910039, 10p.
- (4) **André M, Vidon R, Pruvost C and Tassel P (1997)**. Usages et conditions de fonctionnement des petits véhicules utilitaires (EUREV-PVU). Report INRETS-LEN9708, Bron, France, 51 p.
- (5) **André M (2004)**. The ARTEMIS European driving cycles for measuring car pollutant emissions. *Science of The Total Environment* Vol. 334-335, p. 73-84.
- (6) **Green J M and Barlow T J (2002)**. TRAMAQ – Vehicle operating profiles. Draft Report. TRL. Crowthorne (UK), 52p.
- (7) **Effa R C and Larsen L C (1993)**. Development of Real-World Driving Cycles for Estimating Facility-Specific Emissions from Light-Duty Vehicles. *Air and Waste Manag. Assoc. Conf.* - Pasadena, California, 18-20 October, 20 p.
- (8) **Austin C T, DiGenova F J, Carlson T R, Joy R W, Gianoli K A and Lee J M (1993)**. Characterization of Driving Patterns and Emissions from Light-Duty Vehicles in California. Sacramento (CA, USA): California Air Resources Board. Final Report N° A932-185, 290p.
- (9) **Younglove T, Barth M, Pela A, Yotter E, Sherman J and Gruszecki J (1998)**. The Sacramento instrumented vehicle study – overview". 8th CRC Workshop, San Diego, CA, 23p.
- (10) **Pela A, Yotter E, Younglove T and Barth M (1998)**. Real time quantification of emission activity factors (EAF) by household vehicles. 8th CRC Workshop. San Diego, CA, 16p.
- (11) **Levine C, Younglove T and Barth M (2000)**. Interaction of temperature, humidity, driver preferences and refrigerant type on air conditioning compressor usage. *J. Air & Waste Managt Ass.* Vol. 50, pp 1759-1768.
- (12) **Jung B, Stewart S J, Wong J, Taylor (2000)**. Driving behaviour and cold transient fuel consumption in the Vancouver area. AireCare Research Centre. Ottawa. Report. 46p.
- (13) **Huai T., S.D. Shah, J.W. Miller, T. Younglove, D. Chernich and Ayala A (2006)**. Analysis of heavy-duty diesel truck activity and emissions data. *Atmos. Environment*, Vol. 40, p. 2333-2344.
- (14) **André M, Garrot B, Roynard Y, Vidon R, Tassel P and Perret P (2005)**. Operating conditions of buses in use in the Ile-de-France region of France for the evaluation of pollutants emissions. *Atmos. Environment*. Vol. 69, p. 2411-2420.
- (15) **André M (1999)**. Vehicle use statistics for the design of a de-polluting device., in *French*, Bron, France: INRETS, Report LTE9929, 119p.
- (16) **André M (2001)**. Analysis of the high power phases recorded on board vehicles in actual use. Bron, France: INRETS, Report LTE0113, 29p.
- (17) **André M (2005)**. Analysis of the real-world driving through on-board data recorded on vehicles in actual use. Bron, France: INRETS, Report LTE0524, 44p.
- (18) **Roumégoux J P, André M, Vidon R, Perret P and Tassel P (2004)**. Fuel consumption and CO2 emission from the auxiliary equipment: air conditioning and alternator. in *French*, Bron, France: INRETS, report LTE0428, 28p.
- (19) **Neale V L, Dingus T A, Klauer S G, Sudweeks J and Goodman M (2005)**. An overview of the 100-car naturalistic study and findings. In Proc. of the Int. Techn. Conf. on Enhanced Safety of Vehicles, June 6-9, Washington, DC. 10p.

References

- (20) **Wolf J, Guensler R, Frank L and Ogle J (2000)**. The use of electronic travel diaries and vehicle instrumentation packages in the Year 2000 Atlanta Regional Household Travel Survey. 9th Intern. Assoc. of Travel Behaviour Research Conf., Queensland, Australia, July 2-7, 13p.
- (21) **Schönfelder S, Li H, Guensler R, Ogle J and Axhausen K W (2005)**. Analysis of Commute Atlanta Instrumented Vehicle GPS data: Destination Choice Behavior and Activity Spaces, *Arbeitsberichte Verkehrs- und Raumplanung*, 304, IVT, ETH, Zürich, 27p.
- (22) **Gortan L and Cirillo F (2001)**. The ATENA project: an integrated solution of Advanced Vehicle Technology and Telematics to Environmental Impact. 5th Intl Conf.: Internal Combustion Engine, Capri. Paper 2001-01-84, Istituto Motori, C.N.R., Naples, Italy, p 61-70.
- (23) **Gühnemann A, Schäfer R P, Thiessenhusen K U and Wagner P (2004)**. New approaches to traffic monitoring and management by floating car data. 10th World Conf. On Transp. Research, Istanbul, 19p.
- (24) <http://www.vtti.vt.edu/>
- (25) <http://www.its.leeds.ac.uk/facilities/icity/>
- (26) **Perotti M and Bomba G (2003)**. A low-cost smart data logger for optimum powertrain design. 4th Int. Conf. on Control and Diagnostics in Autom. Appl., June, Sestri Levante (Genova), Italy.
- (27) **EL Faouzi N-E and Lesort J -B (1995)**. Travel Time Estimation on Urban Networks from Traffic Data and On-Board Trip Characteristics., .Proceedings of the second World Congress on ITS, Yokohama, Japan, pp. 88-93.
- (28) **EL Faouzi N -E (1997)**. Heterogeneous data source fusion for impedance indicators, *IFAC Symposium on Transportation Systems*, Chania, Greece, Volume 3, pp 1375-1380.
- (29) **EL Faouzi N -E., Eds. (2003)**. *Multiform Traffic Data Collection and Data Fusion in Road Traffic Engineering*. Proceedings of the INRETS workshop, N°87 INRETS publishing.
- (30) **EL Faouzi N -E (2004)**. Data fusion in road traffic engineering: An overview. Proceedings of SPIE - The International Society for Optical Engineering, Orlando, FL, pp. 360-371.
- (31) **EL Faouzi N -E (2006)**. Bayesian and evidential approaches for traffic data fusion: methodological issues and case study. Presented at the 85th Transportation Research Board Meeting.
- (32) **Asakura Y, Tanabe J and Lee Y H (2000)**. Characteristics of positioning data for monitoring travel behaviour. 7th World Congress on I.T.S., Torino, Italy.
- (33) **Federal Highway Administration (FHA) (1996)**. ITS Data Fusion. Report N° WA-RD 4010.1, September 1996.
- (34) **Ygnace J -L. et al. (2001)**. *Travel Time/Speed Estimates on the French Rhone Corridor Network Using Cellular Phones as Probes: STRIP Project*. Final Report, European Community Research Program Serti, December 2001.
- (35) **Inchingolo B (2006)**. Traffic surveillance tools. [in French] Proceedings of the real time traffic information Workshop, CETE Méditerranée - DGERI – IRD.